



NX 400h+

NX 450h+

Gasoline-Electric

Lexus Hybrid Drive

***HYBRID VEHICLE
DISMANTLING
MANUAL***

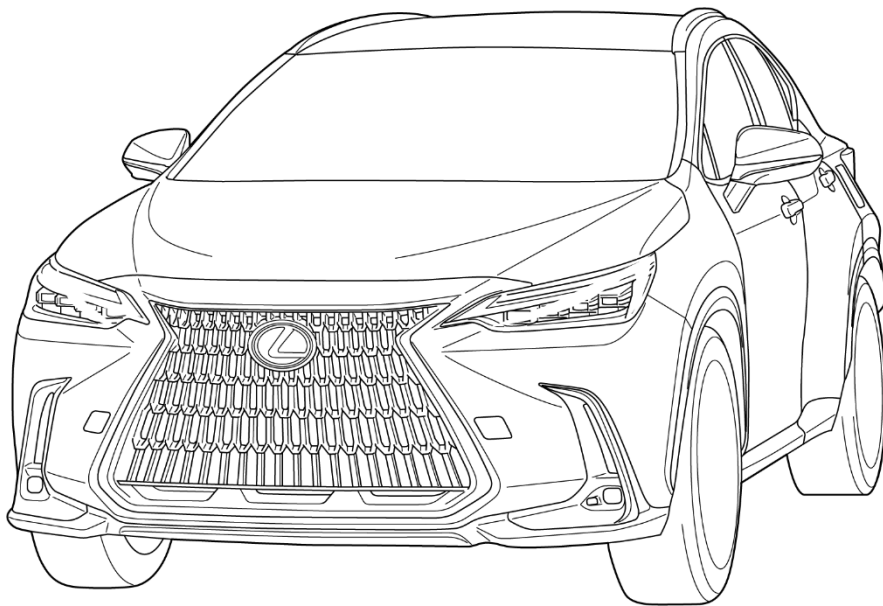

Foreword

This guide was developed to educate and assist dismantlers in the safe handling of Lexus NX400h+/NX450h+ gasoline-electric hybrid vehicles. NX400h+/NX450h+ dismantling procedures are similar to other non-hybrid Lexus vehicles with the exception of the high voltage electrical system. It is important to recognize and understand the high voltage electrical system features and specifications of the Lexus NX400h+/NX450h+, as they may not be familiar to dismantlers.

High voltage electricity powers the A/C compressor, electric motors, generator, and inverter/converter. All other conventional automotive electrical devices such as the head lights, radio, and gauges are powered from a separate 12 Volt auxiliary battery. Numerous safeguards have been designed into the NX400h+/NX450h+ to help ensure the high voltage, approximately 355.2 Volt, Lithium-ion (Li-ion) Hybrid Vehicle (HV) battery pack is kept safe and secure in an accident.

The Lithium-ion battery pack contains sealed batteries that are similar to rechargeable batteries used in some battery operated power tools and other consumer products. The electrolyte is absorbed in the cell plates and will not normally leak out even if the battery is cracked. If the electrolyte is leaking, do not touch any leaked liquid because it could be the organic electrolyte that contains carbonate ester-based. If contact is unavoidable, wipe up the liquid using a cloth while wearing rubber gloves, goggles and an organic solvent mask. Do not leave electrolyte-contaminated cloths unattended. Please contaminated cloths in an appropriate airtight container and dispose of them according to local regulations.

High voltage cables, identifiable by orange insulation and connectors, are isolated from the metal chassis of the vehicle.

Additional topics contained in the guide include:

- Lexus NX400h+/NX450h+ identification.
- Major hybrid component locations and descriptions.

By following the information in this guide, dismantlers will be able to handle NX400h+/NX450h+ hybrid-electric vehicles as safely as the dismantling of a conventional gasoline engine automobile.

© 2021 Toyota Motor Corporation

All rights reserved. This book may not be reproduced or copied, in whole or in part, without the written permission of Toyota Motor Corporation.

Table of Contents

<u>About the NX400h+/NX450h+</u>	<u>1</u>
<u>NX400h+/NX450h+ Identification</u>	<u>3</u>
<u>Exterior</u>	<u>4</u>
<u>Interior</u>	<u>5</u>
<u>Engine Compartment</u>	<u>6</u>
<u>Hybrid Component Locations & Descriptions</u>	<u>7</u>
<u>Specifications</u>	<u>9</u>
<u>Lexus Hybrid Drive Operation</u>	<u>11</u>
<u>Vehicle Operation</u>	<u>11</u>
<u>Hybrid Vehicle (HV) Battery Pack and Auxiliary Battery</u>	<u>12</u>
<u>HV Battery Pack</u>	<u>12</u>
<u>Components Powered by the HV Battery Pack</u>	<u>12</u>
<u>HV Battery Pack Recycling</u>	<u>13</u>
<u>Auxiliary Battery</u>	<u>13</u>
<u>High Voltage Safety</u>	<u>14</u>
<u>High Voltage Safety System</u>	<u>14</u>
<u>Service Plug Grip</u>	<u>15</u>
<u>Precaution to be observed when dismantling the vehicle</u>	<u>17</u>
<u>Necessary Items</u>	<u>17</u>
<u>Spills</u>	<u>18</u>
<u>Dismantling the vehicle</u>	<u>19</u>
<u>Removal of HV battery</u>	<u>26</u>

About the NX400h+/NX450h+

The NX400h+/NX450h+ contains a gasoline engine, an electric motor, and a developed large capacity Li-ion battery. It is the Lexus hybrid that allows the HV battery to be plugged-in and charged by an external power source.

The two hybrid power sources are stored on board the vehicle:

1. Gasoline stored in the fuel tank for the gasoline engine.
2. Electricity stored in a large capacity externally chargeable high voltage Hybrid Vehicle (HV) battery assembly for the electric motor.

Depending on the driving conditions, one or both sources are used to power the vehicle. The following illustration demonstrates how the NX400h+/NX450h+ operates in various driving modes.

EV (Electric Vehicle) Mode:

- ❶ A plug-in charge control system has been adopted, which allows electrical power to be supplied to the HV battery from external power source such as an electrical socket or charger.
- ❷ When the HV battery is sufficiently charged, the vehicle will basically run on the power of the motor.
- ❸ If the vehicle exceeds 135 km/h or accelerates suddenly when traveling in plug-in EV mode, the gasoline engine and motor work together to power the vehicle.

HV (Hybrid Vehicle) Mode:

- ④ During light acceleration at low speeds, the vehicle is powered by the electric motor. The gasoline engine is shut off.
- ⑤ During normal driving, the vehicle is powered mainly by the gasoline engine. The gasoline engine also powers the generator to recharge the battery assembly and to drive the motor.
- ⑥ During full acceleration, such as climbing a hill, both the gasoline engine and the electric motor power the vehicle.
- ⑦ During deceleration, such as when braking, the vehicle regenerates the kinetic energy from the wheels to produce electricity that recharges the battery assembly.
- ⑧ While the vehicle is stopped, the gasoline engine and electric motor are off, however the vehicle remains on and operational.

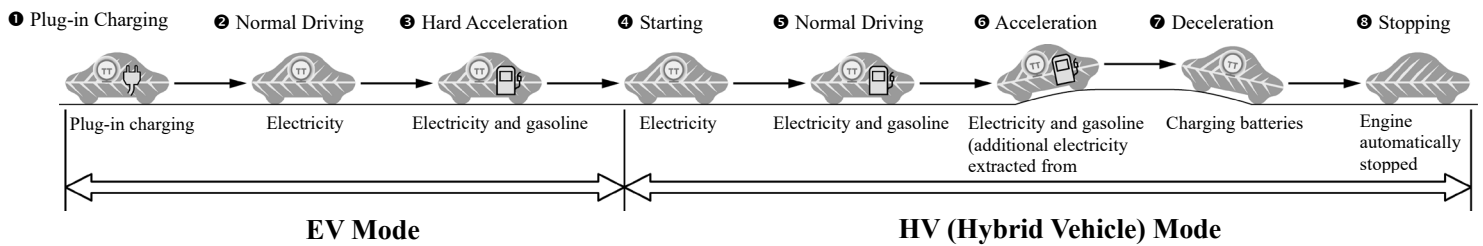

NX400h+/NX450h+ Identification

In appearance, the NX400h+/NX450h+ is nearly identical to the conventional, non-hybrid Lexus NX. The NX400h+/NX450h+ is a 5-door wagon. Exterior, interior, and engine compartment illustrations are provided to assist in identification.

The alphanumeric 15 character Vehicle Identification Number (VIN) is provided on the left side windshield cowl, floor under the right side front seat and left side B pillar.

Example VIN:

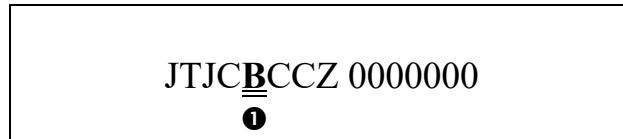

A NX400h+/NX450h+ is identified by the 5th alphanumeric character of the VIN.

①	Engine Series	Drive Type
B	A25B-FXS	2WD
K	A25A-FXS	AWD

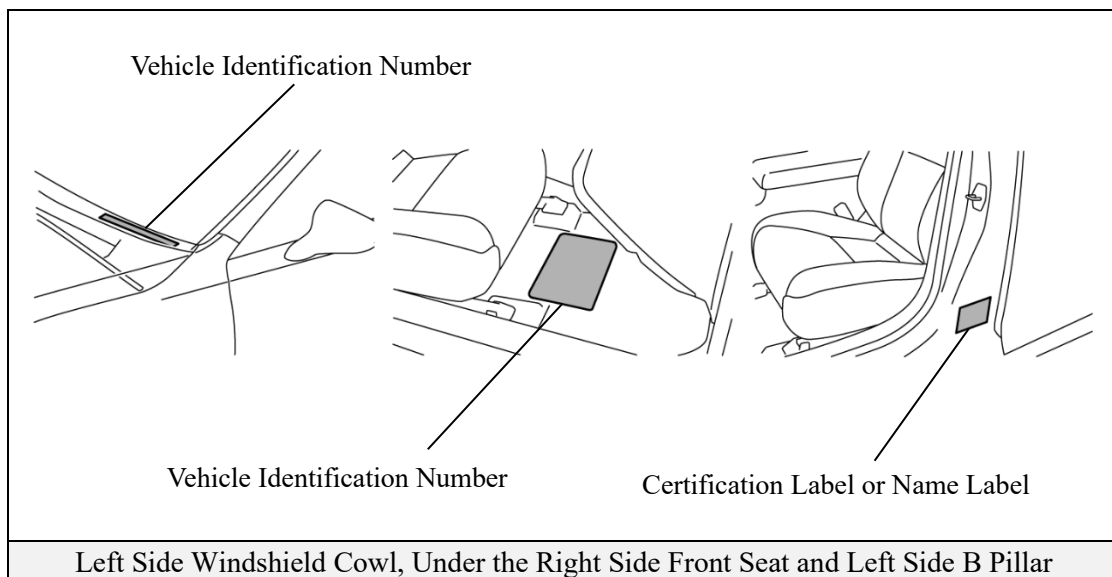

Exterior

- ❶ NX400h+/NX450h+ logos on the back door.
- ❷ Gasoline fuel filler door located on left side rear quarter panel.
- ❸ Charge inlet door located on the right side rear quarter panel.

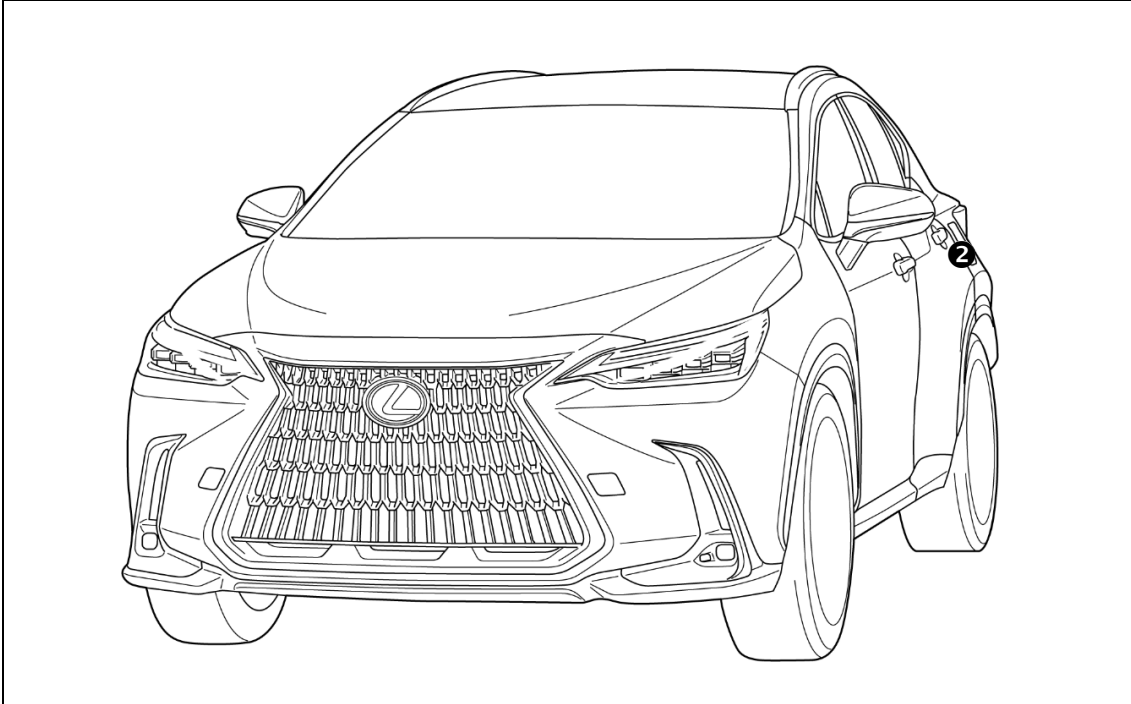

Exterior Front and Left Side View

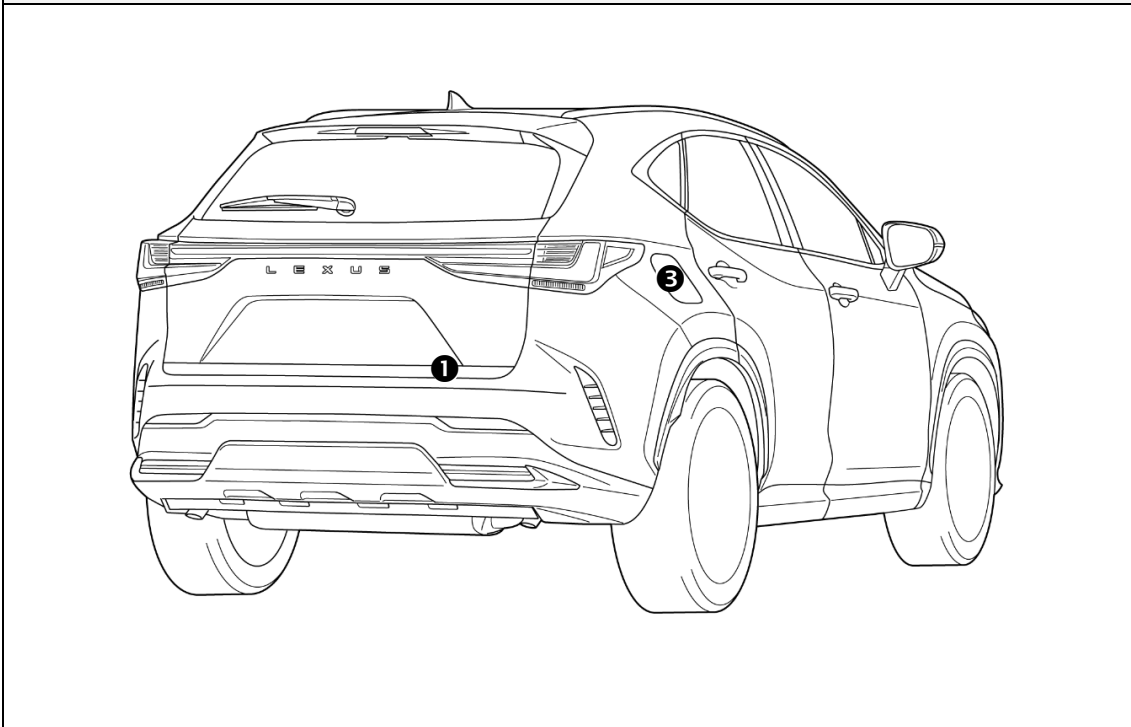

Exterior Rear and Right Side View

Interior

- ④ The instrument cluster (hybrid system indicator, **READY** indicator and warning lights) located in the dash behind the steering wheel, is different than the one on the conventional, non-hybrid NX.
- ⑤ In Place of a tachometer, a hybrid system indicator is used to show power output.

NOTICE:

If the vehicle is shut off, the instrument cluster gauges will be “blacked out”, not illuminated.

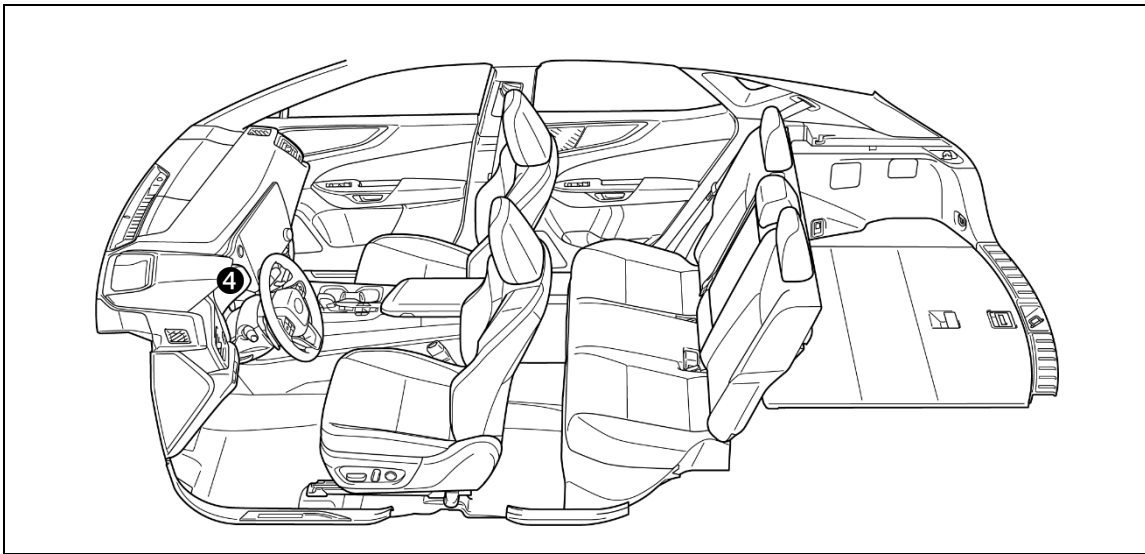

Interior View

- ④ Models with headup display

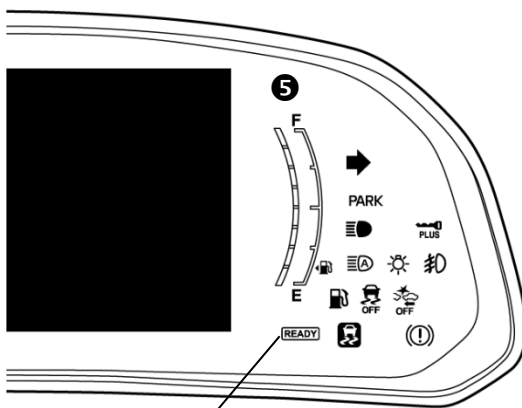

READY Indicator

- ④ Except models with headup display

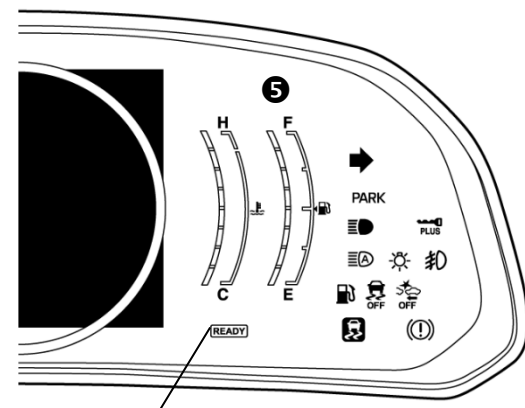

READY Indicator

Combination Meter View

Engine Compartment

- ⑥ 2.5-liter aluminum alloy gasoline engine.
- ⑦ Orange colored high voltage power cables.
- ⑧ Charge inlet door located on the right side rear quarter panel.

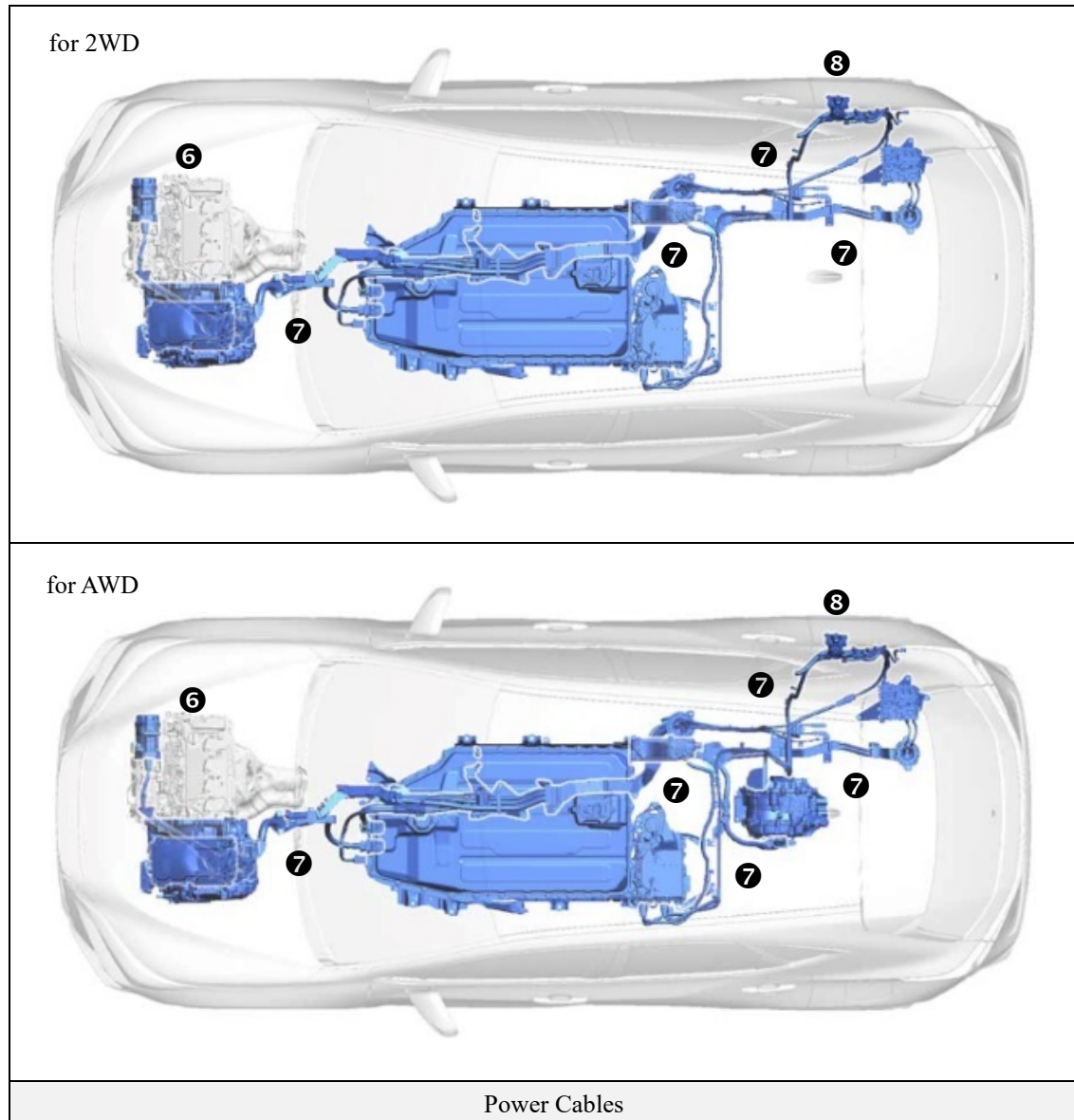

Hybrid Component Locations & Descriptions

Component	Location	Description
12 Volts Auxiliary Battery ❶	Luggage Compartment Area	Supplies electricity to the electrical components.
Hybrid Vehicle (HV) Battery Pack ❷	Undercarriage	<ul style="list-style-type: none"> •Supplies electrical power to MG1, MG2 and MGR*1 in accordance with the driving conditions of the vehicle. •Recharged by MG1, MG2 and MGR*1 in accordance with the SOC and the driving conditions of the vehicle.
Power Cables ❸	Undercarriage and Engine Compartment	Connects the HV battery, hybrid motor control inverter assembly, hybrid vehicle transaxle assembly, rear drive unit (rear traction motor with transaxle assembly)*1 and compressor with motor assembly.
Inverter/ Converter ❹	Engine Compartment	<ul style="list-style-type: none"> • Converts the direct current from the boost converter into alternating current for MG1, MG2 and MGR*1, and vice versa (from AC to DC). •Boosts the HV battery nominal voltage of DC 355.2 Volts up to a maximum voltage of DC 650 Volts and vice versa (steps down DC 650 Volts to DC 355.2 Volts).
Gasoline Engine ❺	Engine Compartment	Provides two functions: 1) Powers vehicle. 2) Powers generator to recharge the HV battery pack. The engine is started and stopped under control of the vehicle computer.

Component	Location	Description
Front Electric Motor ⑥	Engine Compartment	<ul style="list-style-type: none"> •MG2, which is driven by electrical power from MG1 and the HV battery, generates motive force for the drive wheels. •During braking, or when the accelerator pedal is not depressed, it generates high-voltage electricity to recharge the HV battery.
Electric Generator ⑦	Engine Compartment	MG1, which is driven by the engine, generates high-voltage electricity in order to operate MG2, MGR*1 and charge the HV battery. Also, it functions as a starter to start the engine.
A/C Compressor (with inverter) ⑧	Engine Compartment	3-phase high voltage AC electrically driven motor compressor.
DC-DC Converter for 12 Volts Auxiliary Battery ⑨	Cabin Area, Under Rear Seat	Steps down the HV battery nominal voltage of DC 355.2 Volts to approximately DC 14 Volts in order to supply electricity to the electrical components, as well as to recharge the auxiliary battery.
Rear Electric Motor ⑩*1	Rear Sub-Frame	<ul style="list-style-type: none"> •MGR, which is driven by electrical power from MG1 and the HV battery, generates motive force for the drive wheels. •When the accelerator pedal is not depressed, it generates high-voltage electricity to recharge the HV battery.
Fuel Tank and Fuel Line ⑪	Undercarriage and Center	The fuel tank provides gasoline via a fuel line to the engine. The fuel line is routed under the center of vehicle.

*Numbers in the component column apply to the illustrations on the following page.

*1: for AWD

Specifications

Gasoline Engine: 131 / 134 / 136 kW, 2.5-liter Aluminum Alloy Engine

Electric Motors

Front: 134 kW, Permanent Magnet Synchronous Motor

Rear: 40 kW, Permanent Magnet Synchronous Motor

Transmission: Automatic Only

HV Battery: 355.2 Volt Sealed Li-ion-Battery

Curb Weight: 4,255-4,387 lbs / 1,930-1,990 kg
4,387-4,519 lbs / 1,990-2,050 kg (for AWD)

Fuel Tank: 12.1 Imp gals/14.5 U.S. gals/55 liters

Frame Material: Steel Unibody

Body Material: Steel Panels

Seating Capacity: 5 passenger

for 2WD

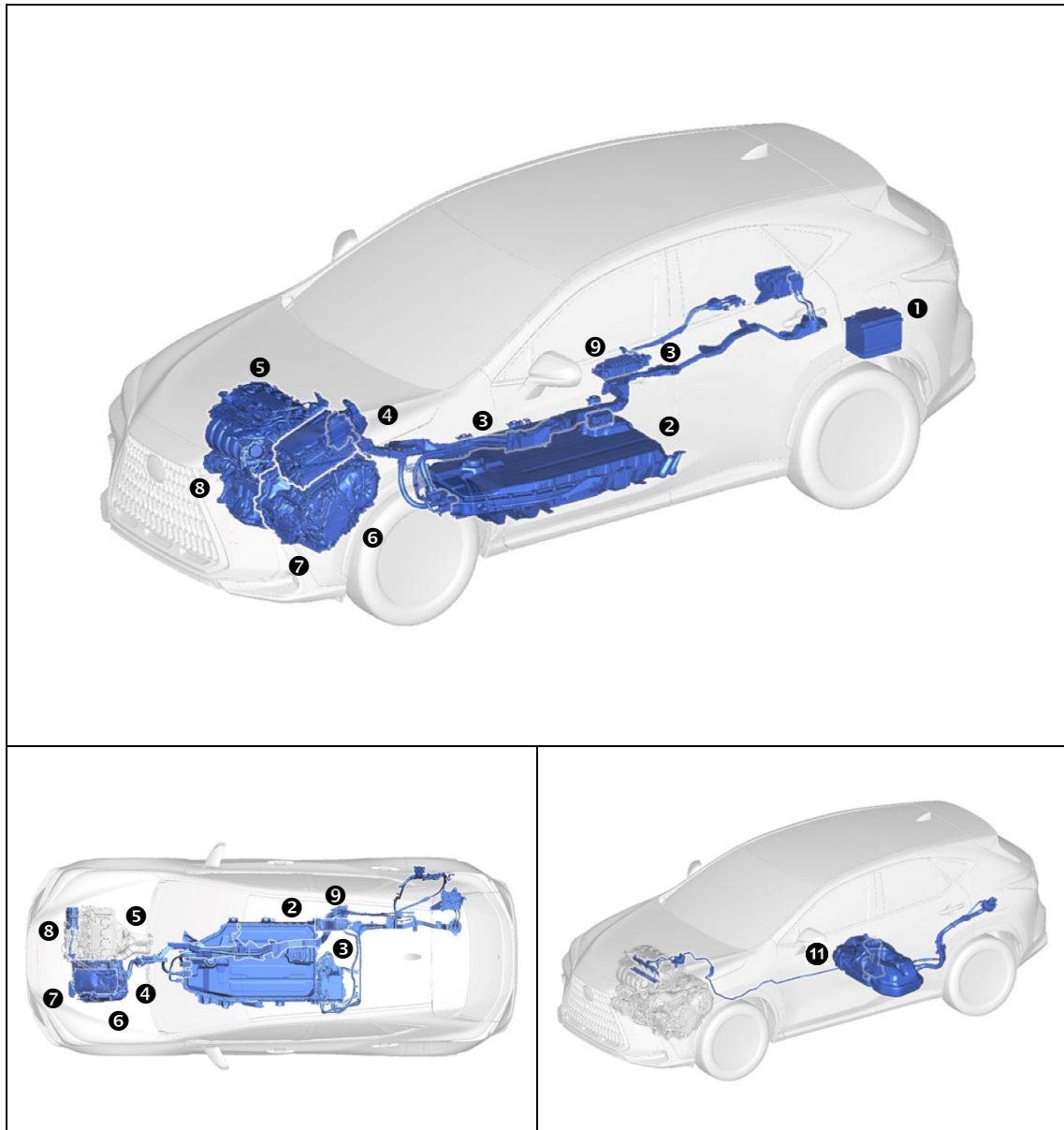

for AWD

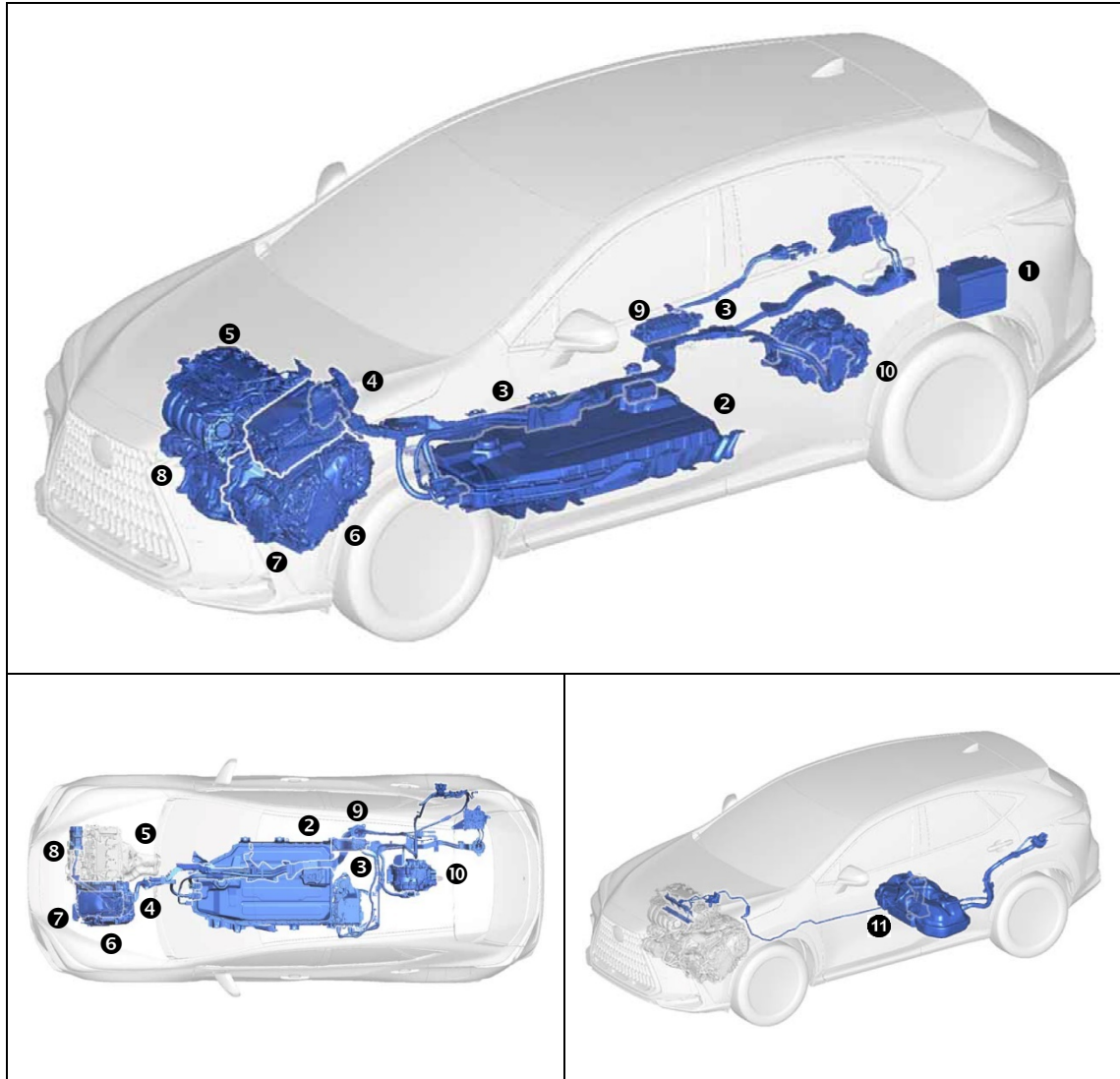

Lexus Hybrid Drive Operation

Once the **READY** indicator is illuminated in the instrument cluster, the vehicle may be driven. However, the gasoline engine does not idle like a typical automobile and will start and stop automatically. It is important to recognize and understand the **READY** indicator provided in the instrument cluster. When illuminated, it informs the driver that the vehicle is on and operational even though the gasoline engine may be off and the engine compartment is silent.

Vehicle Operation

- With the NX400h+/NX450h+, the gasoline engine may stop and start at any time while the **READY** indicator is on.
- Never assume that the vehicle is shut off just because the engine is off. Always look for the **READY** indicator status. The vehicle is shut off when the **READY** indicator is off.

The vehicle may be powered by:

1. The electric motors only.
2. A combination of both the electric motors and the gasoline engine.

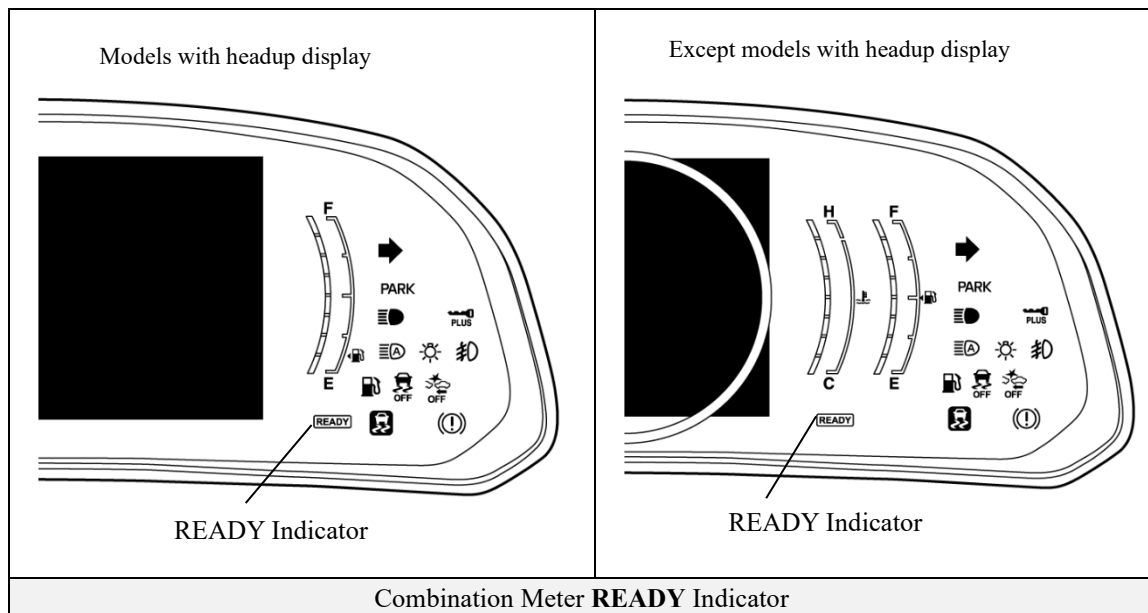

Hybrid Vehicle (HV) Battery Pack and Auxiliary Battery

The NX400h+/NX450h+ features a high voltage Hybrid Vehicle (HV) battery pack that contains sealed Lithium-ion (Li-ion) battery cells.

HV Battery Pack

- The HV battery pack is enclosed in a metal case and is rigidly mounted to the undercarriage. The metal case is isolated from high voltage.
- The HV battery pack consists of 96 low voltage (3.7 Volts) Li-ion battery cells connected in series to produce approximately 355.2 Volts. Each Li-ion battery module is non-spillable and sealed in a metal case.
- The electrolyte used in the Li-ion battery module is an alkaline mixture of potassium and sodium hydroxide. The electrolyte is absorbed into the battery cell plates and will not normally leak, even in a collision.

HV Battery Pack	
Battery pack voltage	355.2 Volts
Number of Li-ion battery cells in the pack	96
Li-ion battery module voltage	3.7 Volts

Components Powered by the HV Battery Pack

- Front Electric Motor
- Rear Electric Motor
- Power Cables
- A/C Compressor
- Electric Generator
- Inverter/Converter
- DC-DC Converter for 12 Volts Auxiliary Battery

HV Battery Pack Recycling

- The HV battery assembly is recyclable. Contact either your Lexus Distributor or the nearest Lexus dealer.

Auxiliary Battery

- The NX400h+/NX450h+ also contains a sealed lead-acid 12 Volts battery. This 12 Volts auxiliary battery powers the vehicle electrical system similar to a conventional vehicle. As with other conventional vehicles, the auxiliary battery is grounded to the metal chassis of the vehicle.
- The auxiliary battery is located under the luggage compartment area. It is concealed by a plastic resin cover on the left side in the battery compartment.

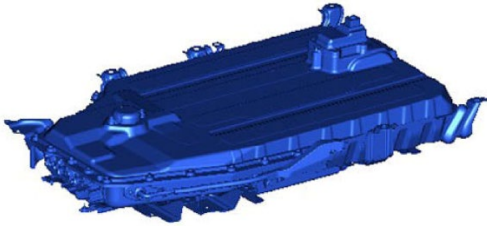
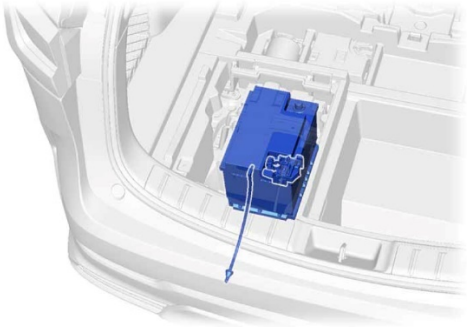
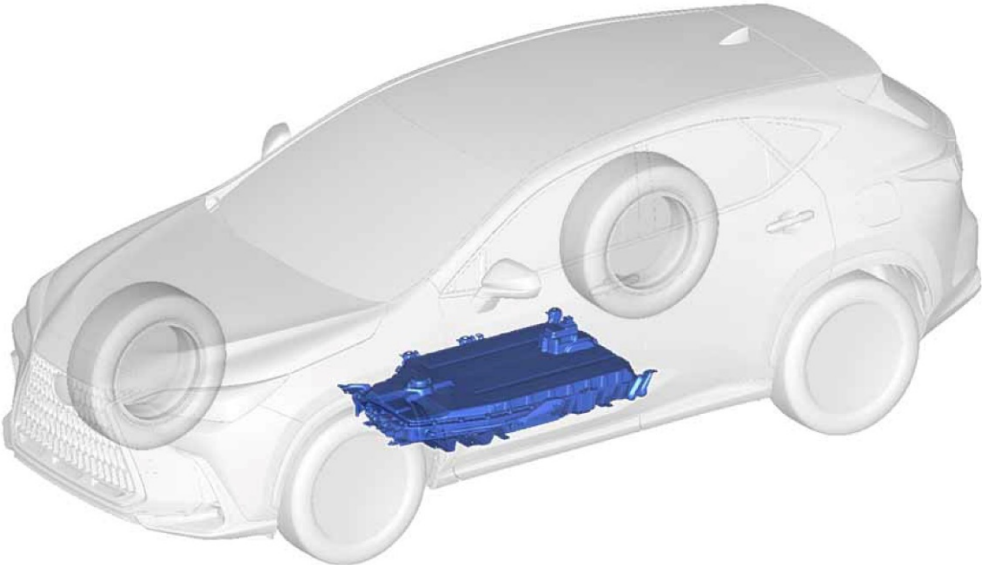
	
355.2 Volts HV Battery Pack	12 Volts Auxiliary Battery Mounted in Luggage Compartment Area (Left Side)
	
HV Battery Pack Mounted in Undercarriage	

High Voltage Safety

The HV battery pack powers the high voltage electrical system with DC electricity. Positive and negative orange colored high voltage power cables are routed from the battery pack, under the vehicle floor pan, to the inverter/converter, A/C compressor, DC/DC converter. The inverter/converter contains a circuit that boosts the HV battery voltage from 355.2 to 650 Volts DC. The inverter/converter creates 3-phase AC to power the motors. Power cables are routed from the inverter/converter to each high voltage motors (front and rear electric motors, and electric generator). The following systems are intended to help keep occupants in the vehicle and emergency responders safe from high voltage electricity:

High Voltage Safety System

- Positive and negative high voltage power cables ❶* connected to the HV battery pack are controlled by 12 Volts normally open relays ❷*. When the vehicle is shut off, the relays stop electricity flow from leaving the HV battery pack.



WARNING:

- ***The high voltage system may remain powered for up to 10 minutes after the vehicle is shut off or disabled. To prevent serious injury or death from severe burns or electric shock, avoid touching, cutting, or opening any orange high voltage power cable or high voltage component.***

- Both positive and negative power cables ❶* are insulated from the metal body. High voltage electricity flows through these cables and not through the metal vehicle body. The metal vehicle body is safe to touch because it is insulated from the high voltage components.
- A ground fault monitor ❸* continuously monitors for high voltage leakage to the metal chassis while the vehicle is running. If a malfunction is detected, the hybrid vehicle computer ❹* will a message indicating that the hybrid system is malfunctioning will be displayed on the multi-information display.
- The HV battery pack relays will automatically open to stop electricity flow in a collision sufficient to activate the SRS.

*Numbers apply to the illustration on the following page.

Service Plug Grip

- The high voltage circuit is cut by removing the service plug grip (see page 19)

2WD

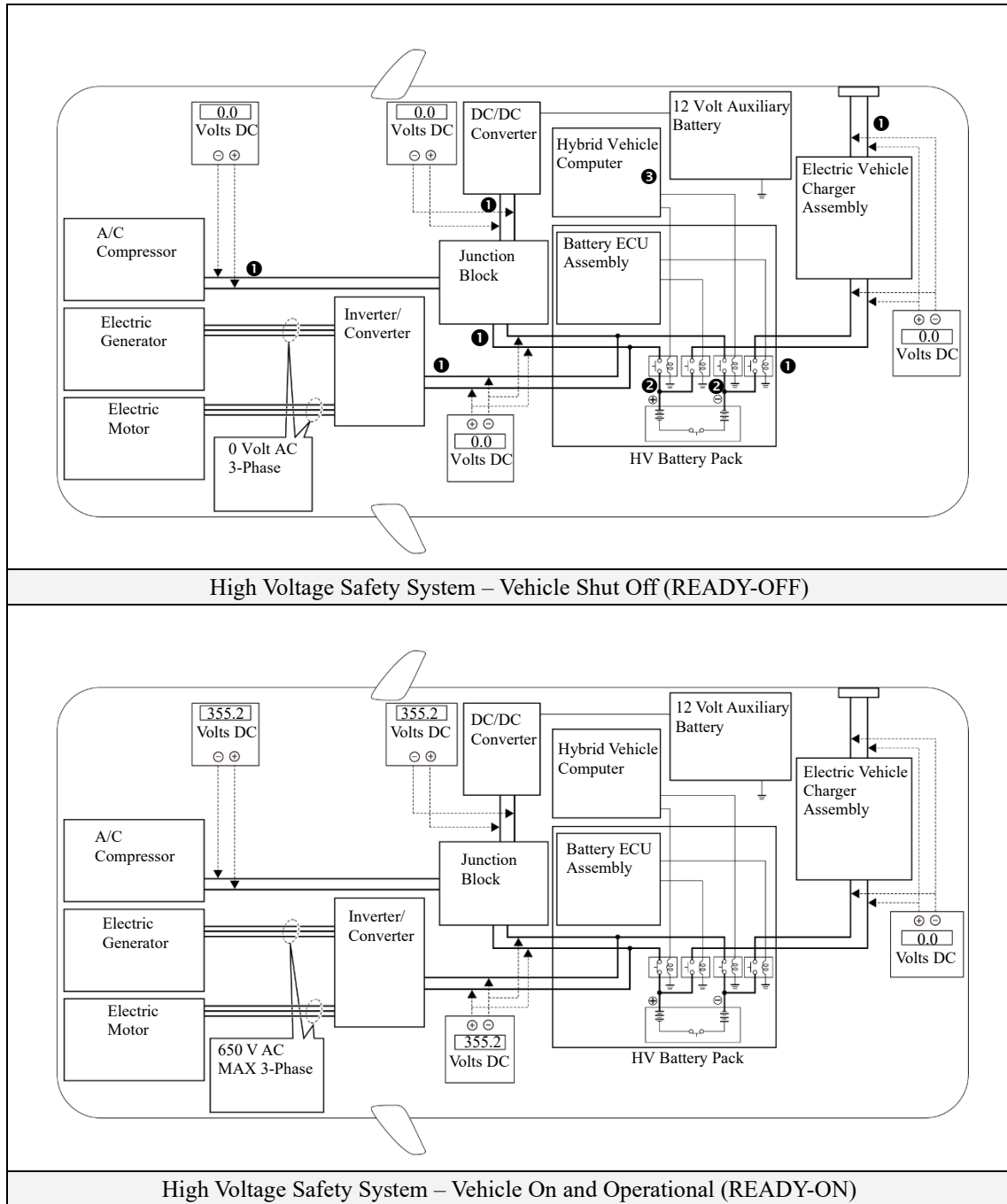

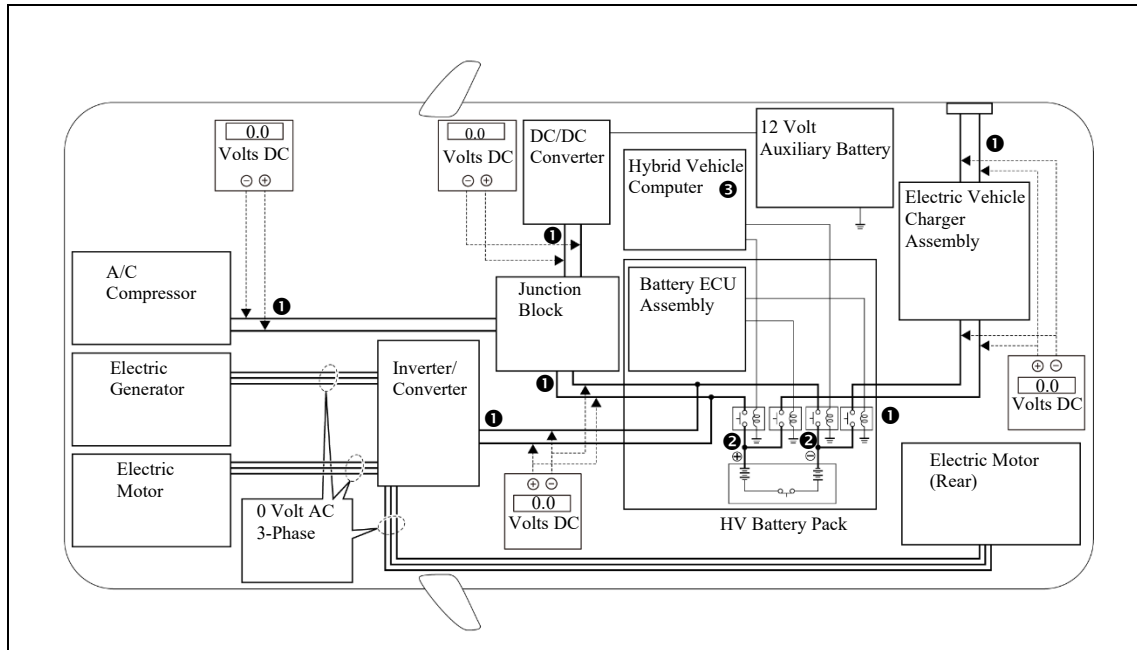

High Voltage Safety System – Vehicle Shut Off (READY-OFF)

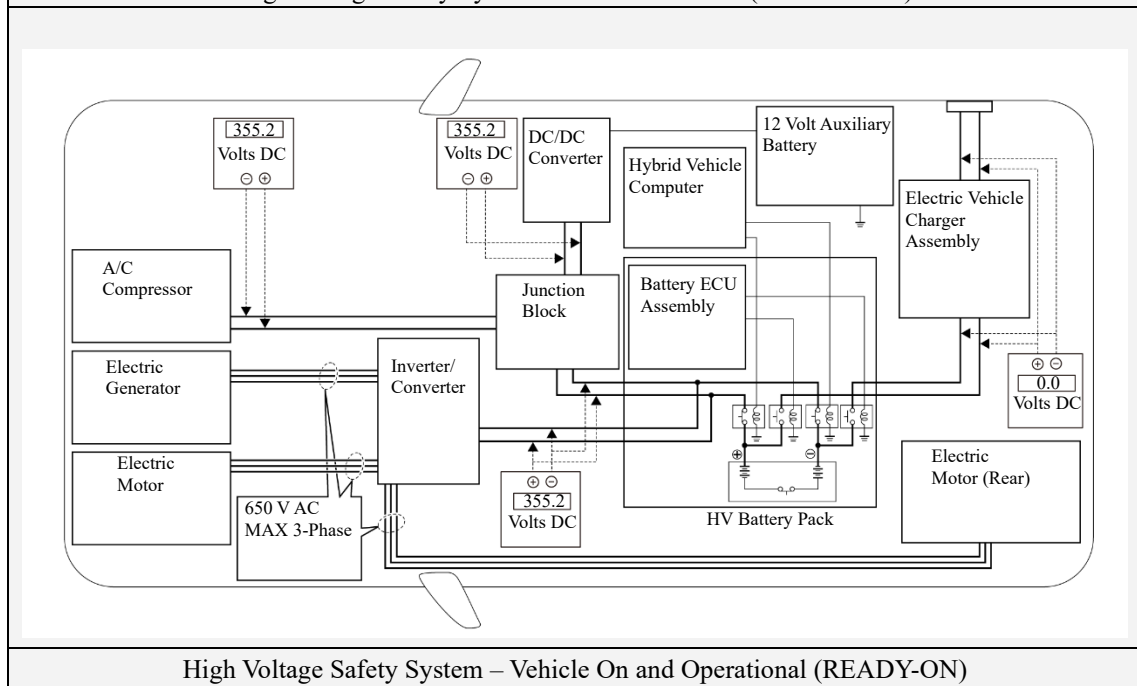

High Voltage Safety System – Vehicle On and Operational (READY-ON)

Precaution to be observed when dismantling the vehicle

- To prevent electric shock, wear insulated gloves when working on wire harnesses and components of the high voltage system.
Before using insulated gloves, be sure to check them for cracks, tears and other types of damage.
- When servicing the vehicle, do not carry metal objects like mechanical pencils or rulers that can be dropped accidentally and cause a short circuit.
- To reduce the risk of electric shock, make sure to remove the service plug grip to cut off the high voltage circuit before servicing the vehicle.
- To reduce the risk of electric shock, make sure to wait at least 10 minutes after removing the service plug grip to fully discharge the high voltage capacitor inside the inverter with converter assembly.
- Do not touch any high voltage wire harnesses, connectors or parts with bare hands.
- Do not touch the terminals of the service plug grip.
- Make sure to insulate the high-voltage connectors and terminals of the HV battery with insulating tape after removing them.
- After removing the service plug grip, put it in your pocket to prevent other technicians from accidentally reconnecting it while you are working on the high-voltage system.
- Before touching a bare high-voltage terminal, wear insulated gloves and use a tester to make sure that the terminal voltage is 0 V.
- Electrolyte leaks may cause acute poisoning if a high concentration of the vapor from the electrolyte is inhaled. In case of inhalation, move the affected person to a place with ample fresh air and let them lie quietly. Seek medical care.
- If the electrolyte comes in contact with your skin, wash the area thoroughly with soap and plenty of water, and seek medical care. If the electrolyte comes in contact with an article of clothing, take it off immediately. Prolonged contact with the electrolyte may cause skin irritation.
- If the electrolyte comes in contact with your eyes, call out loudly for help. Do not rub your eyes. Immediately flush them with a large amount of water for at least 15 minutes and seek medical care.
- If electrolyte is swallowed, seek medical care immediately. Do not induce vomiting, unless instructed by the doctor.
- If the vehicle catches on fire, use an ABC fire extinguisher to extinguish the fire.
Trying to extinguish a fire using only a small amount of water can be more dangerous than effective. Use a substantial amount of water or wait for firefighters.
- Do not allow any foreign matter or water to enter the HV battery.

Necessary Items

- Protective clothing such as insulated gloves (electrically insulated), rubber gloves, helmet, safety goggles, safety shoes and SCBA or protective mask.
- Insulating tape such as electrical tape that has a suitable electrical insulation rating and insulation tool set.
- An electrical tester that is capable of measuring DC 750 Volts or more.

Spills

The NX400h+/NX450h+ contains the same common automotive fluids used in other non-hybrid Lexus vehicles, with the exception of the Li-ion electrolyte used in the HV battery pack. The electrolyte used in the Li-ion battery cells is a flammable organic electrolyte. The electrolyte is absorbed into the battery cell separators, even if the battery cells are crushed or cracked, it is unlikely that liquid electrolyte will leak. Any liquid electrolyte that leaks from a Li-ion battery cell quickly evaporates.



WARNING:

- ***The Li-ion battery contains organic electrolyte. Only a small amount may leak from the batteries which may irritate the eyes, nose, throat, and skin.***
- ***Contact with the vapor produced by the electrolyte may irritate the nose and throat.***
- ***To avoid injury by coming in contact with the electrolyte or vapor, wear personal protective equipment for organic electrolyte including SCBA or protective mask for organic gases.***

- Handle Li-ion electrolyte spills using the following Personal Protective Equipment (PPE):
 - Splash shield or safety goggles. A fold down face shield is not acceptable for acid or electrolyte spills.
 - Rubber gloves or gloves suitable for organic solvents.
 - Apron suitable for organic solvents.
 - Rubber boots or boots suitable for organic solvents.
 - Protective mask for organic gases or SCBA.

Dismantling the vehicle

The following 7 pages contain general instructions for use when working on a NX400h+/NX450h+. Read these instructions before proceeding to the HV battery removal instructions on page 26.



WARNING:

- ***The high voltage system may remain powered for up to 10 minutes after the vehicle is shut off or disabled. To prevent serious injury or death from severe burns or electric shock, avoid touching, cutting, or opening any orange high voltage power cable or any high voltage component.***

1. Shut off the ignition (**READY** indicator is off).
2. Remove battery service cover plate.

a.

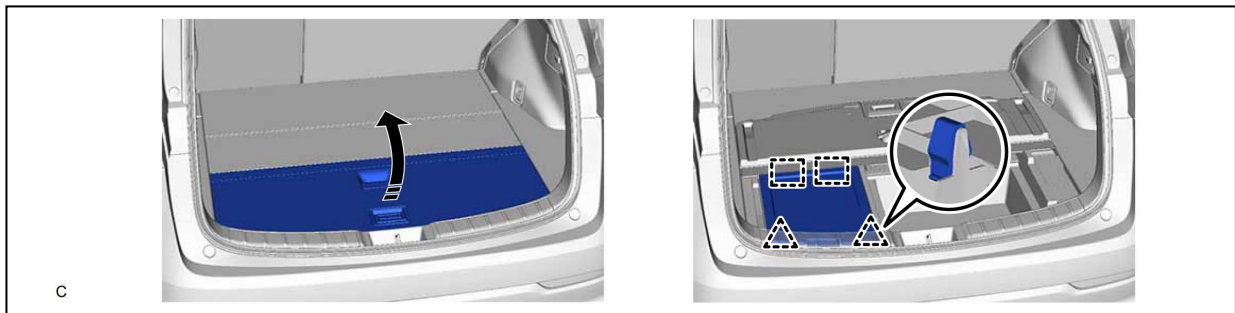

3. Disconnect cable from negative auxiliary battery terminal.

a.

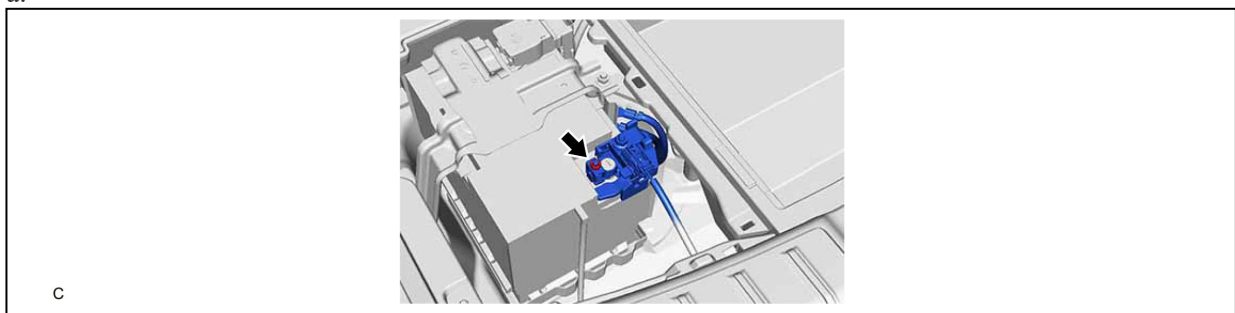

4. Remove console rear end panel sub-assembly

a.

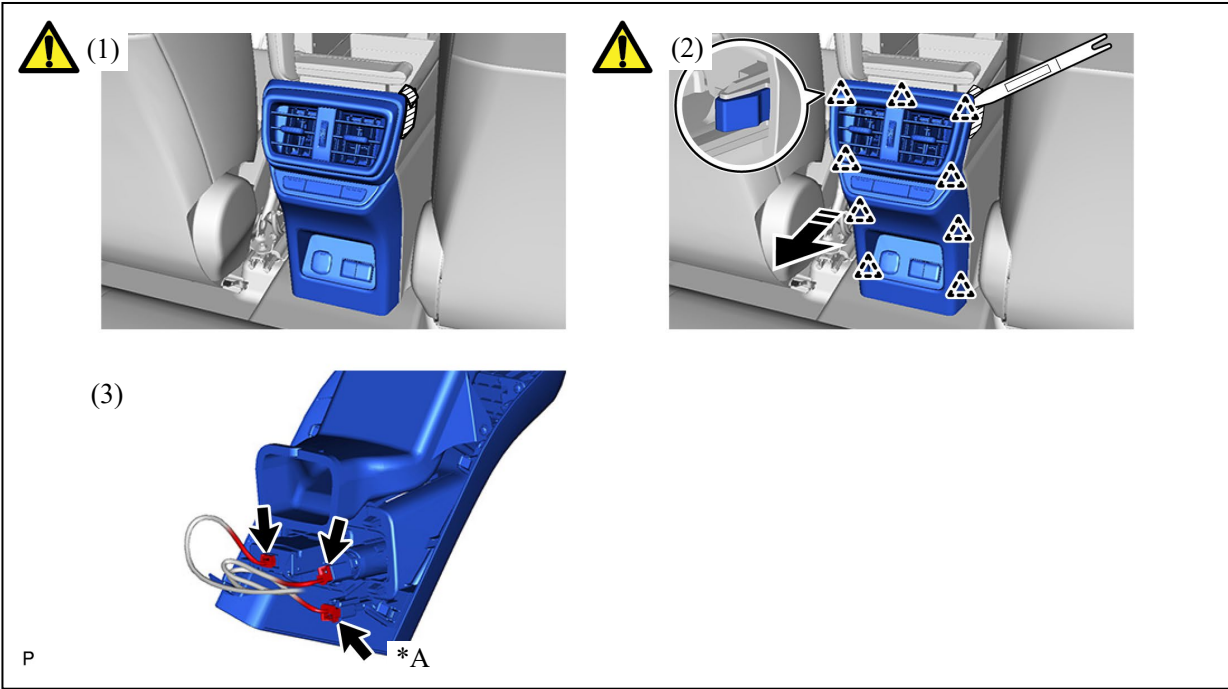

*A	w/ Seat Heater System	—	—
➡	Remove in this Direction	—	—

- (1) Apply protective tape to the area shown in the illustration.
- (2) Using a moulding remover, disengage the 9 clips as shown in the illustration to remove the console rear end panel sub-assembly.
- (3) Disconnect each connector.

5. Remove battery service hole cover

a.

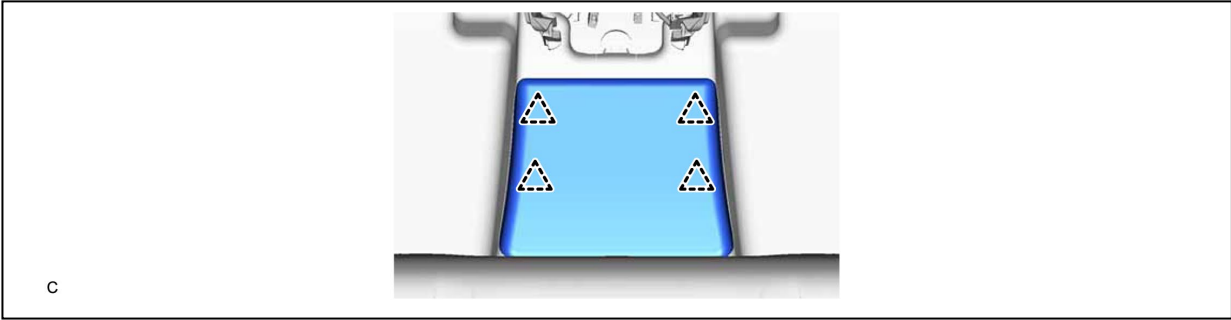

6. Remove front floor service hole cover

a.

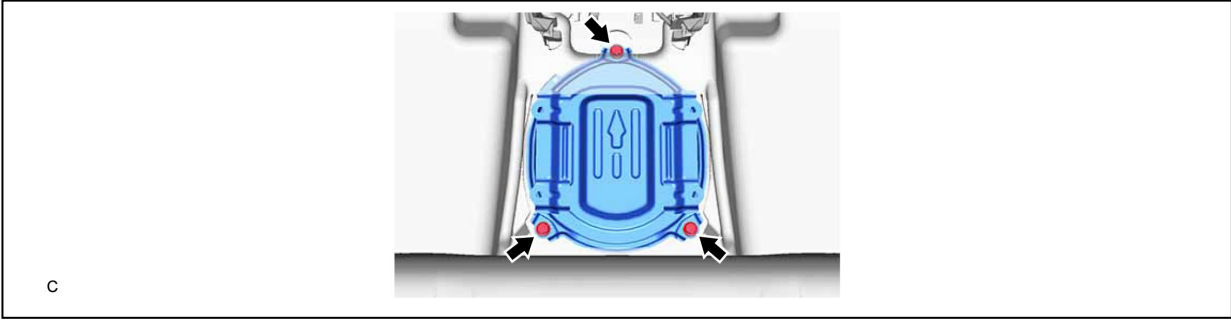

7. Remove No. 2 traction battery cover

a.

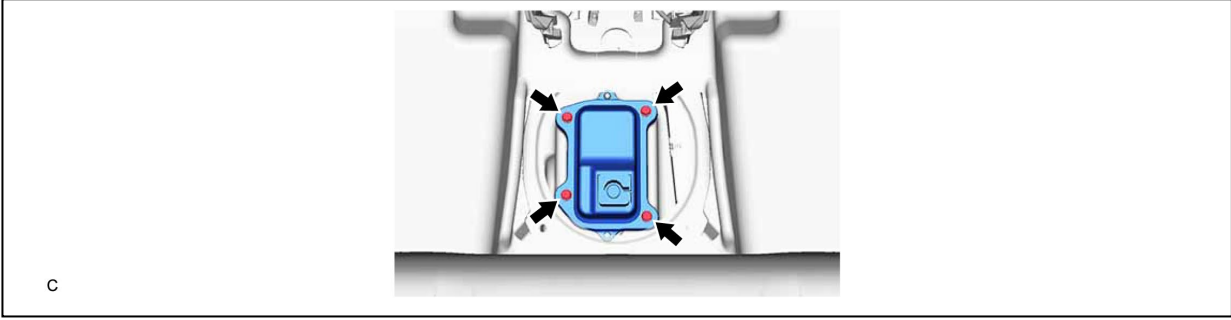

8. Remove service plug grip



CAUTION:

- Be sure to wear insulated gloves.
- Do not inspect or service the high voltage system with the service plug grip installed.
- To reduce the risk of electric shock, make sure to remove the service plug grip to cut off the high voltage circuit before servicing the vehicle.
- To reduce the risk of electric shock, make sure to wait at least 10 minutes after removing the service plug grip to fully discharge the high voltage capacitor inside the inverter with converter assembly.
- Keep the removed service plug grip in your pocket to prevent other technicians from accidentally installing it while you are servicing the vehicle.

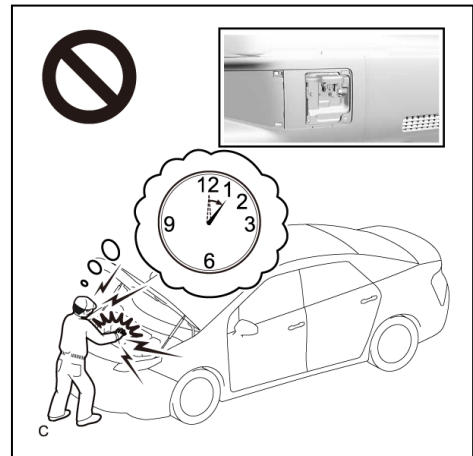
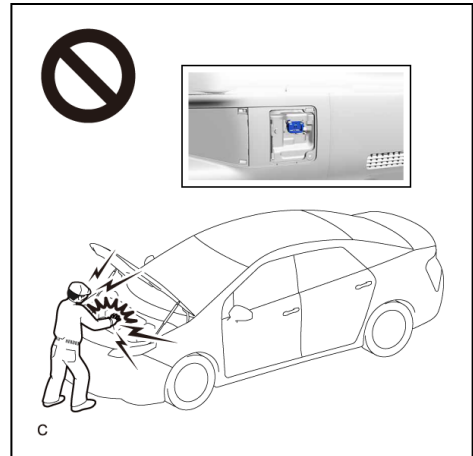



NOTICE:

- After removing the service plug grip, turning the power switch on (READY) may cause a malfunction. Do not turn the power switch on (READY) unless instructed by the repair manual.
- Do not touch the terminals of the service plug grip.
- If the service plug grip has been struck or dropped, replace it.

HINT:

Waiting for at least 10 minutes is required to discharge the high voltage capacitor inside the inverter with converter assembly.

a.

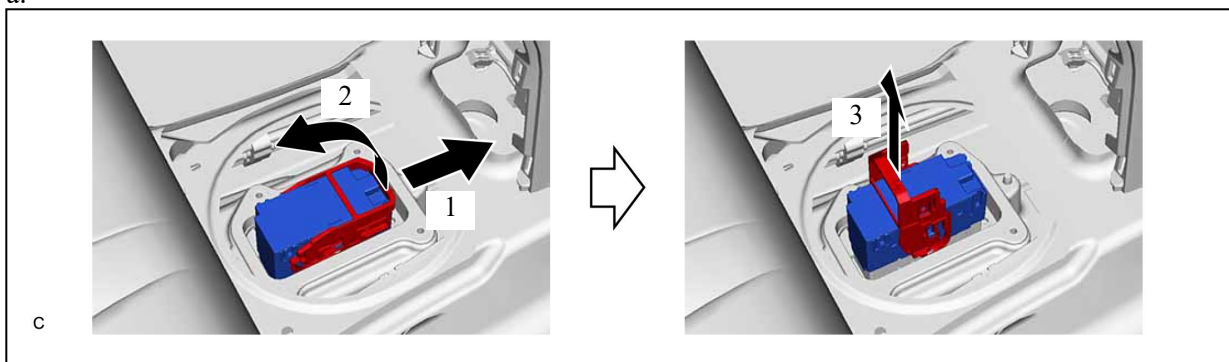

- (1) While wearing insulated gloves, rotate the handle of the service plug grip and remove the service plug grip as indicated by the arrows, in the order shown in the illustration.

CAUTION:

- Do not allow any foreign matter to fall into the HV supply battery assembly.
- Take steps to prevent foreign material from falling into the HV supply battery assembly after removing the service plug grip.

9. Make other staff aware that a high-voltage system is being dismantled by using the following sign:
CAUTION: HIGH-VOLTAGE. DO NOT TOUCH
(see page 25).

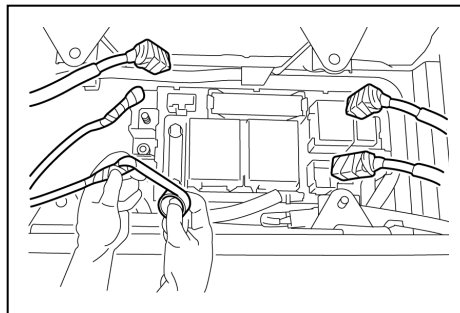

10. If the service plug grip cannot be removed due to damage to the vehicle, remove the **IGP-MAIN NO. 1** fuse.

CAUTION:

This operation shuts off the HV system. Be sure to wear insulated gloves because high voltage is not shut off inside the HV battery. When it is possible to remove the service plug grip, remove it and continue the procedure.

11. After disconnecting or exposing a high-voltage connector or terminal, insulate it immediately using insulating tape. Before disconnecting or touching a bare high-voltage terminal, wear insulated gloves.
12. Check the HV battery and nearby area for leakage. If you find any liquid, wear rubber gloves and goggles, and wipe up the liquid using waste rags etc.
13. If the electrolyte comes into contact with your skin, wash the skin immediately using a large amount of water and a soap. If the electrolyte adheres to any article of clothing, take the clothing off immediately.
14. If the electrolyte comes into contact with your eye(s), call out loudly for help. Do not rub your eye(s). Instead, wash the eye(s) with a large amount of water and seek medical care.
15. With the exception of the HV battery, remove parts by following procedures which are similar to conventional Lexus vehicles. For the removal of the HV battery, refer to the following pages.

Person in charge:

CAUTION:
HIGH-VOLTAGE.
DO NOT TOUCH.

CAUTION:
HIGH-VOLTAGE.
DO NOT TOUCH.

Person in charge:

When performing work on the HV system, fold this sign and put it on the roof of the vehicle.

Removal of HV battery



WARNING:

- *Be sure to wear insulated gloves when handling high-voltage parts.*
- *Even if the vehicle is shut off and the relays are off, be sure to remove the service plug grip before performing any further work.*
- *Power remains in the high voltage electrical system for 10 minutes even after the HV battery pack is shut off because the circuit has a condenser that stores power.*
- *Make sure that the tester reading is 0 Volt before touching any high-voltage terminals which are not insulated.*
- *The SRS may remain powered for up to 90 seconds after the vehicle is shut off or disabled. To prevent serious injury or death from unintentional SRS deployment, avoid cutting the SRS components.*

1. RECOVER REFRIGERANT FROM REFRIGERATION SYSTEM
2. SHUT OFF IGINATION (**READY** indicator is off)
3. BATTERY SERVICE COVER PLATE

a.

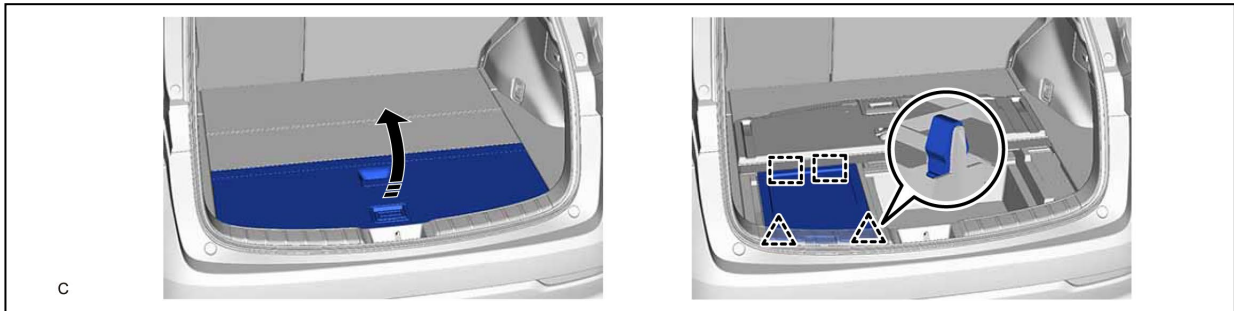

4. DISCONNECT CABLE FROM NEGATIVE AUXILIARY BATTERY TERMINAL

a.

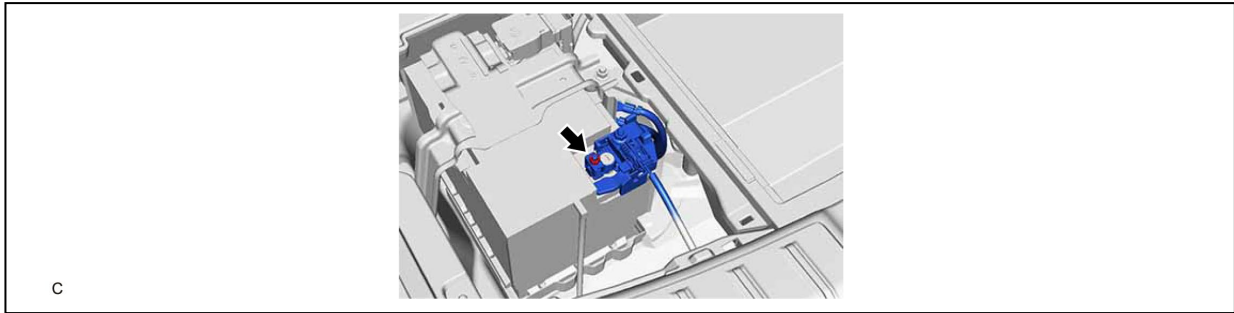

5. REMOVE BATTERY SERVICE HOLE COVER

a.

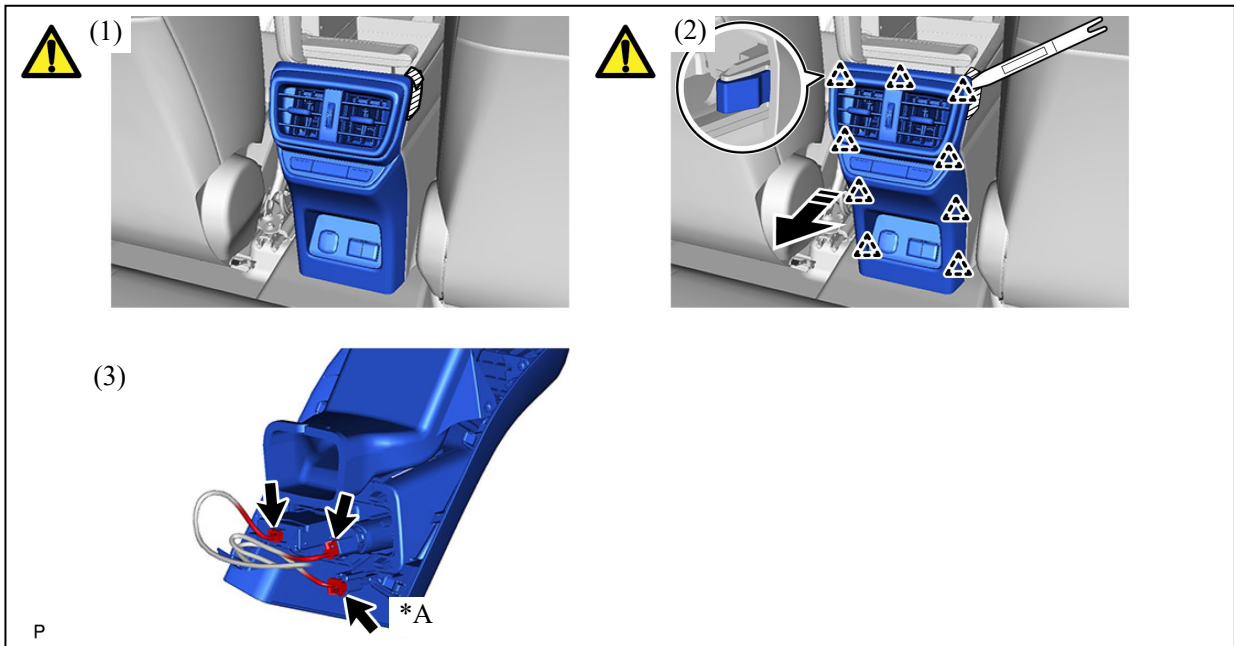

*A	w/ Seat Heater System	—	—
➡	Remove in this Direction	—	—

- (1) Apply protective tape to the area shown in the illustration.
- (2) Using a moulding remover, disengage the 9 clips as shown in the illustration to remove the console rear end panel sub-assembly.
- (3) Disconnect each connector.

6. REMOVE BATTERY SERVICE HOLE COVER

a.

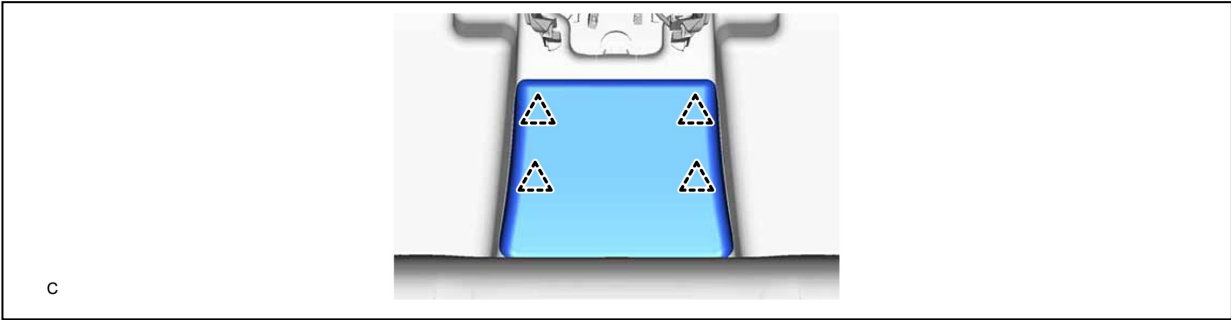

7. REMOVE FRONT FLOOR SERVICE HOLE COVER

a.

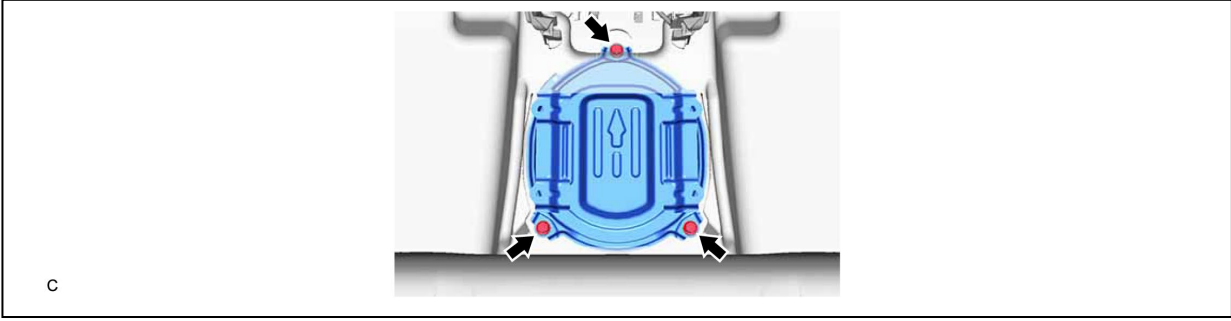

8. REMOVE NO. 2 TRACTION BATTERY COVER

a.

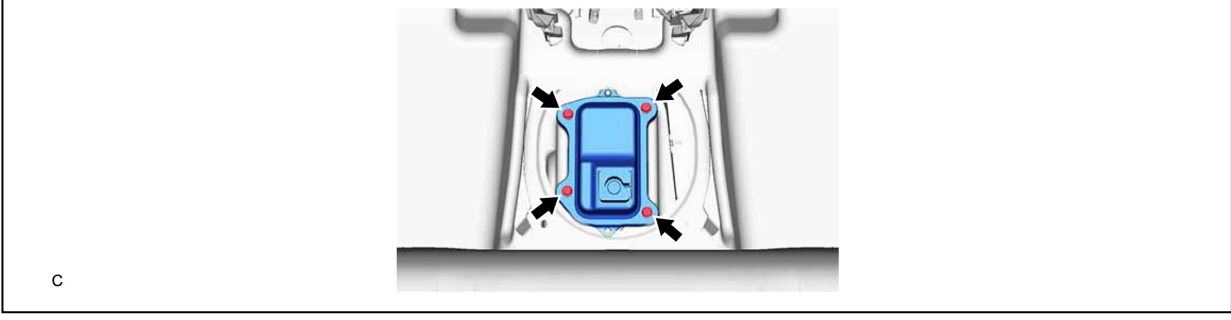

9. REMOVE SERVICE PLUG GRIP

CAUTION:

- Be sure to wear insulated gloves.
- Do not inspect or service the high voltage system with the service plug grip installed.
- To reduce the risk of electric shock, make sure to remove the service plug grip to cut off the high voltage circuit before servicing the vehicle.

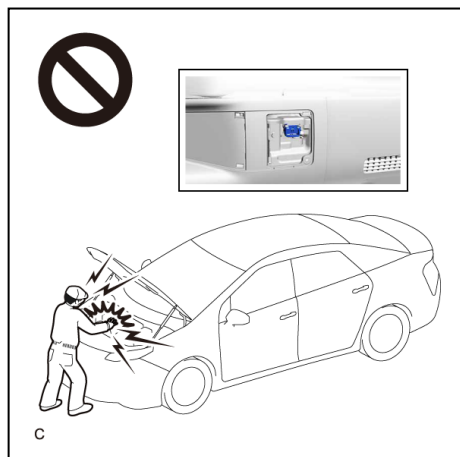

- To reduce the risk of electric shock, make sure to wait at least 10 minutes after removing the service plug grip to fully discharge the high voltage capacitor inside the inverter with converter assembly.
- Keep the removed service plug grip in your pocket to prevent other technicians from accidentally installing it while you are servicing the vehicle.

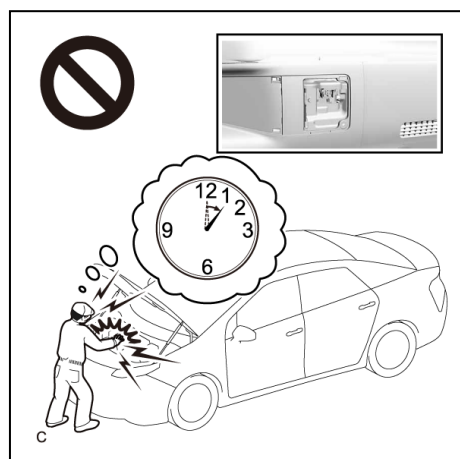



NOTICE:

- After removing the service plug grip, turning the power switch on (READY) may cause a malfunction. Do not turn the power switch on (READY) unless instructed by the repair manual.
- Do not touch the terminals of the service plug grip.
- If the service plug grip has been struck or dropped, replace it.

HINT:

Waiting for at least 10 minutes is required to discharge the high voltage capacitor inside the inverter with converter assembly.

a.

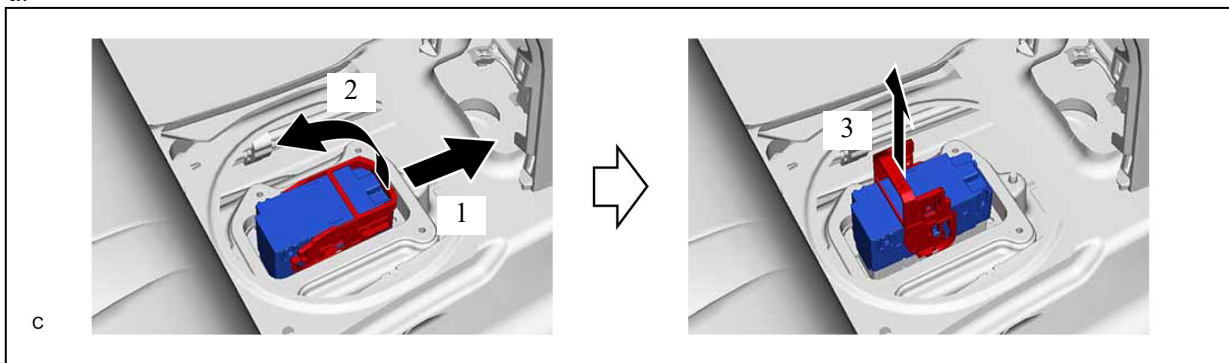

- (1) While wearing insulated gloves, rotate the handle of the service plug grip and remove the service plug grip as indicated by the arrows, in the order shown in the illustration.

CAUTION:

- Do not allow any foreign matter to fall into the HV supply battery assembly.
- Take steps to prevent foreign material from falling into the HV supply battery assembly after removing the service plug grip.

10. REMOVE NO. 2 INVERTER PROTECTOR

a.

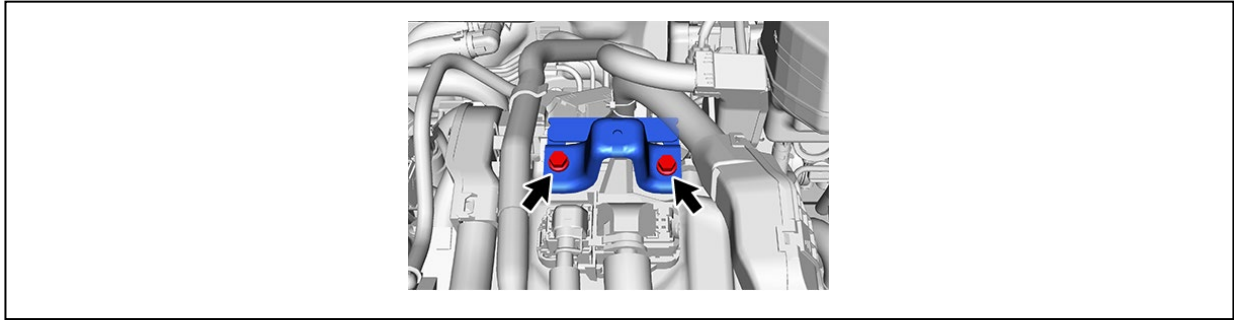

11. REMOVE CONNECTOR COVER ASSEMBLY



CAUTION:

Be sure to wear insulated gloves.

NOTICE:

Do not allow any foreign matter or water to enter the hybrid motor control inverter assembly.

a.



(1), (2)

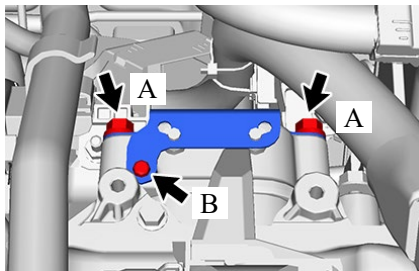

(1) Remove the 2 bolts (A).

(2) Using a T25 "TORX" socket wrench, remove the bolt (B) and connector cover assembly from the hybrid motor control inverter assembly.

13. CHECK TERMINAL VOLTAGE



CAUTION:
Be sure to wear insulated gloves.

a.



(1)

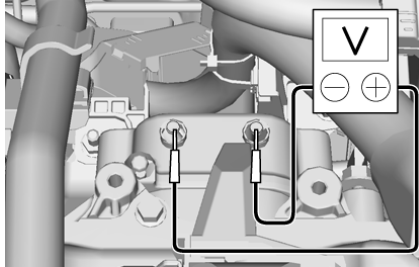

(1) Using a voltmeter, measure the voltage between the terminals of the 2 phase connectors.

Standard voltage: 0 V

NOTICE:

Do not allow any foreign matter or water to enter the hybrid motor control inverter assembly.

HINT:

Use a measuring range of DC 750 Volt or more on the voltmeter.

14. REMOVE NO. 2 ENGINE UNDER COVER ASSEMBLY

a.

c

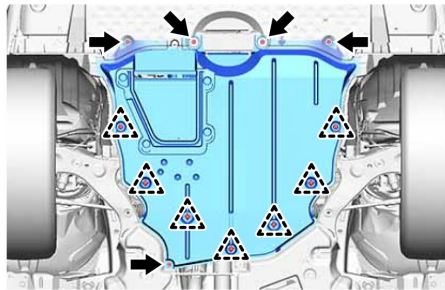

15. REMOVE FRONT FLOOR COVER LH

a.

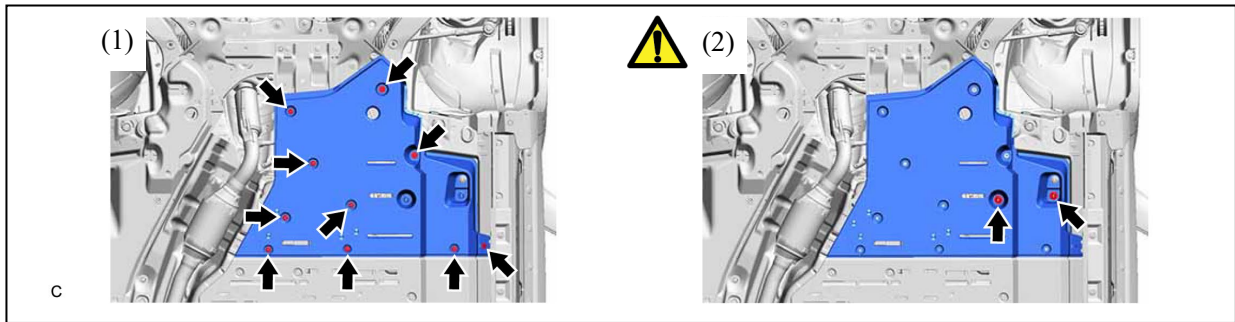

(1) Remove the 2 bolts, screw and 7 clips.

(2) Turn the 2 clips and remove the front floor cover LH from the vehicle body.

NOTICE:

If the 2 clips are not turned when the front floor cover LH is removed, the front floor cover LH or stud bolt may be damaged.

HINT:

Do not remove the clips from the front floor cover LH.

16. REMOVE NO. 2 FLOOR UNDER COVER

a.

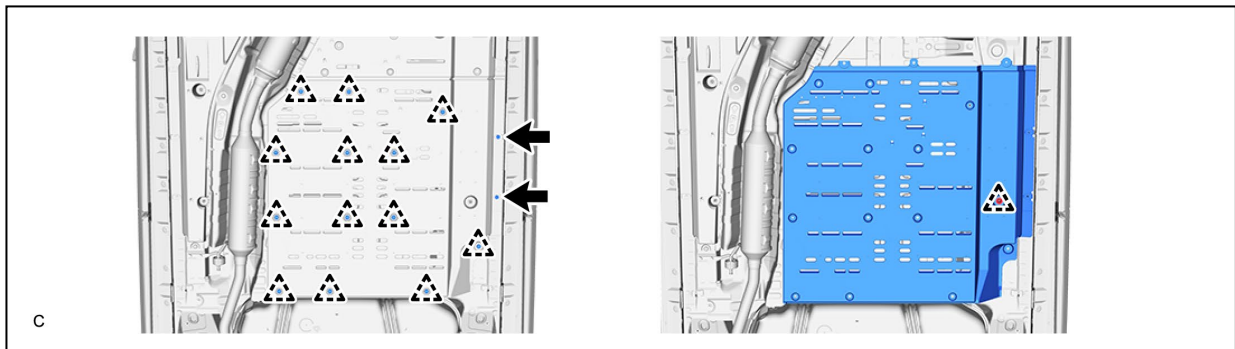

17. REMOVE FRONT FLOOR COVER RH

a.

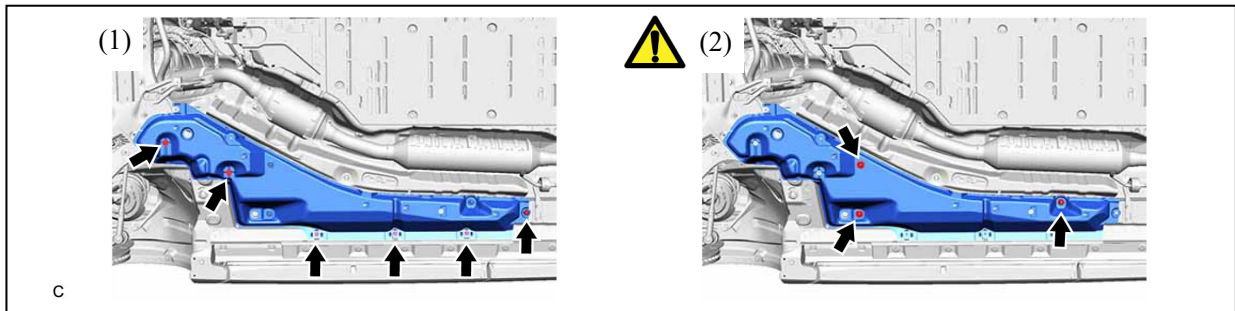

(1) Remove the 2 bolts, 3 screws and clip.

(2) Turn the 3 clips and remove the front floor cover RH from the vehicle body.

NOTICE:

If the 3 clips are not turned when the front floor cover RH is removed, the front floor cover RH or stud bolt may be damaged.

HINT:

Do not remove the clips from the front floor cover RH.

18. REMOVE ENGINE UNDER COVER HEAT INSULATOR

a.

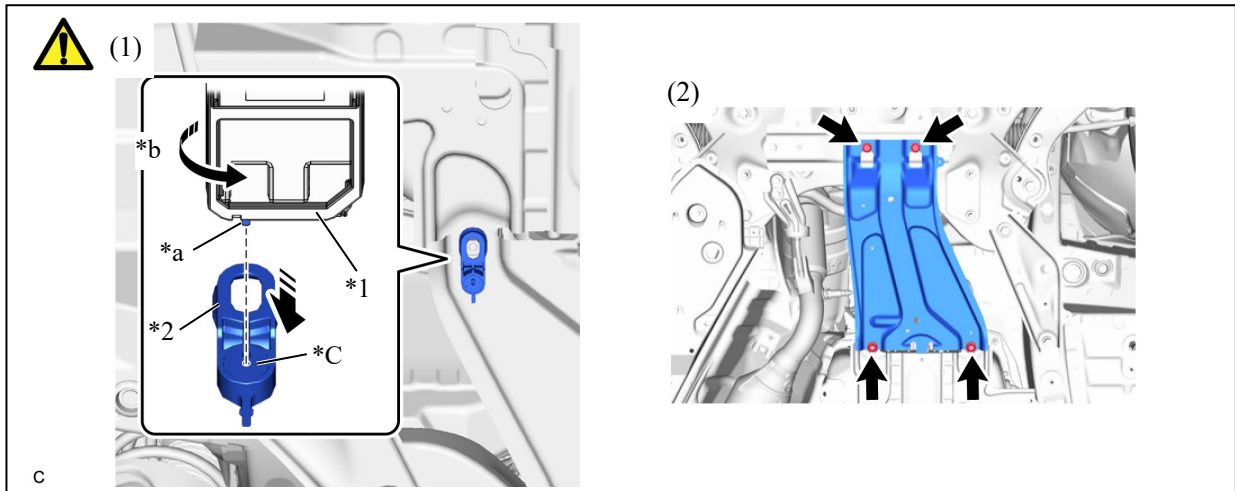

(1) Insert the projection of the service plug grip and turn the button of the No.23 traction battery bracket counterclockwise to release the lock to remove the No.23 traction battery bracket.

(2) Remove the 2 bolts, 2 nuts and engine under cover heat insulator.

19. REMOVE FRONT EXHAUST PIPE ASSEMBLY



CAUTION:

To prevent burns, do not touch the engine, exhaust pipe or other high temperature components while the engine is hot.

a.

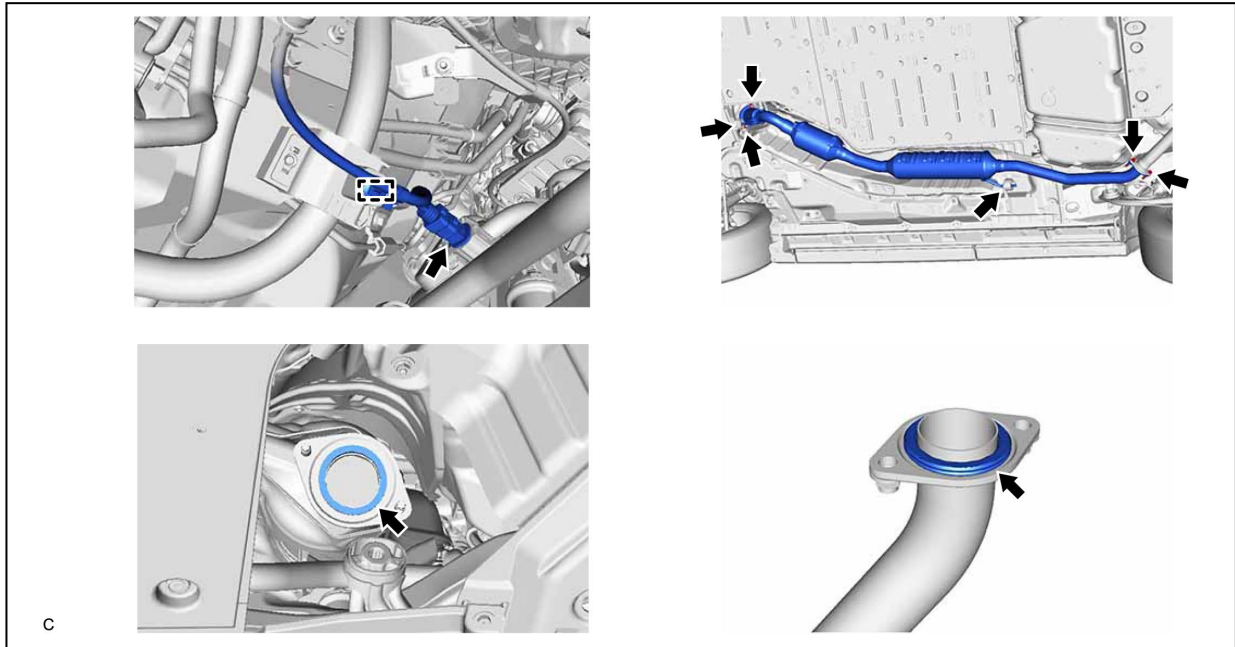

20. REMOVE FRONT NO. 2 FLOOR HEAT INSULATOR

a.

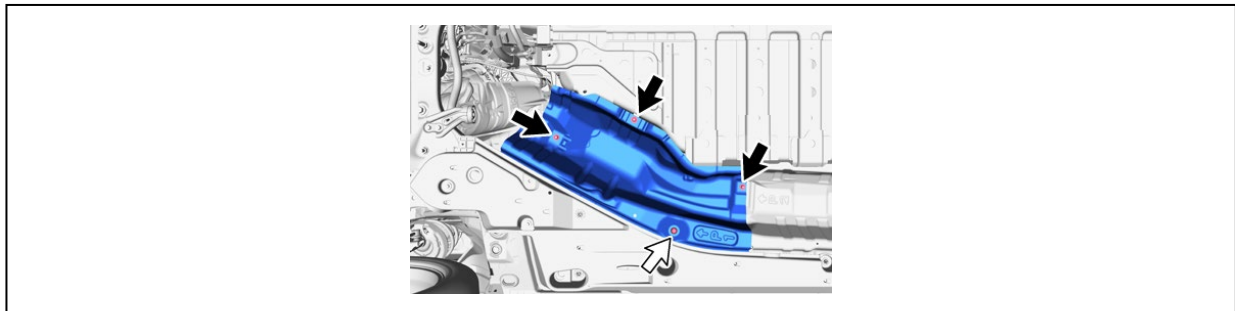

21. REMOVE FRONT LOWER NO. 1 FLOOR HEAT INSULATOR

a.

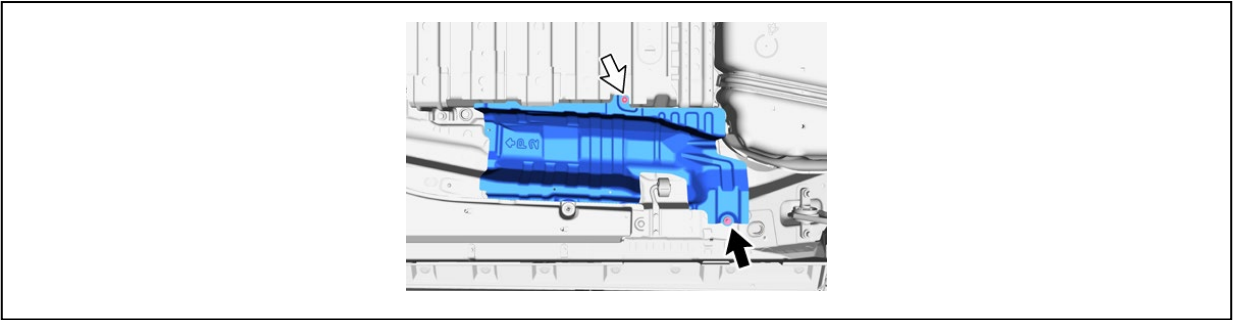

22. DISCONNECT NO. 3 LIQUID TUBE

	<p>CAUTION: Be sure to wear insulated gloves and protective goggles.</p> <p>NOTICE: Seal the openings of the disconnected parts with vinyl tape to prevent entry of moisture and foreign matter.</p>
--	---

a.

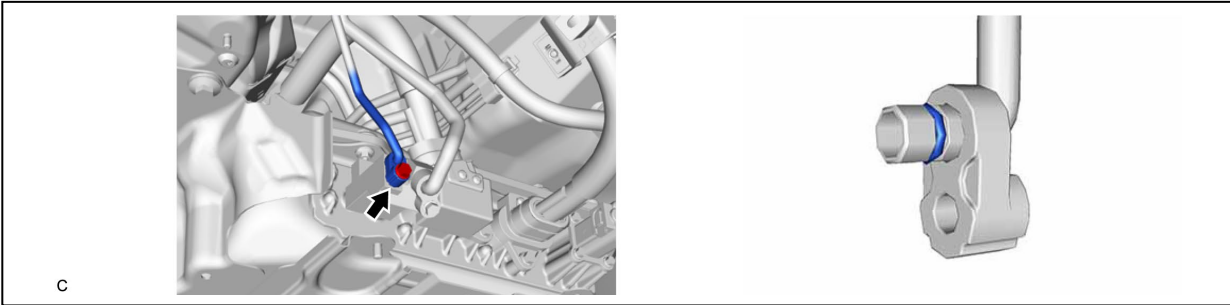

23. DISCONNECT NO. 9 DISCHARGE TUBE

	<p>CAUTION: Be sure to wear insulated gloves and protective goggles.</p> <p>NOTICE: Seal the openings of the disconnected parts with vinyl tape to prevent entry of moisture and foreign matter.</p>
---	--

a.

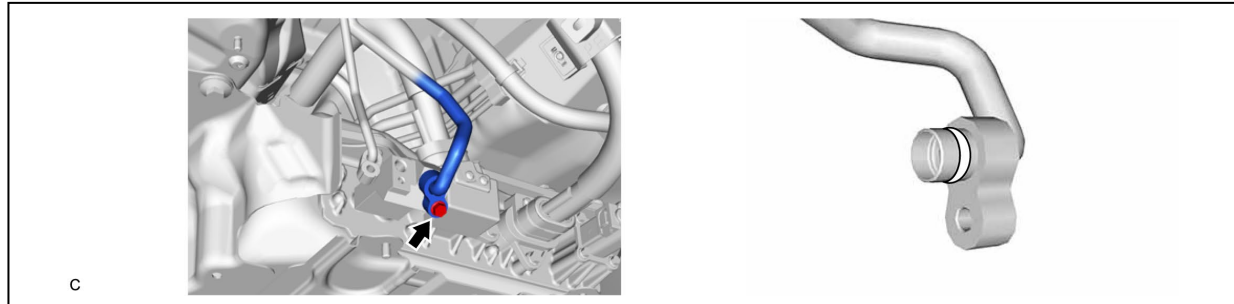

24. DISCONNECT HV FLOOR UNDER WIRE

	<p>CAUTION: Be sure to wear insulated gloves and protective goggles.</p> <p>NOTICE: Insulate the disconnected terminals and connector with insulating tape.</p>
--	---

a.

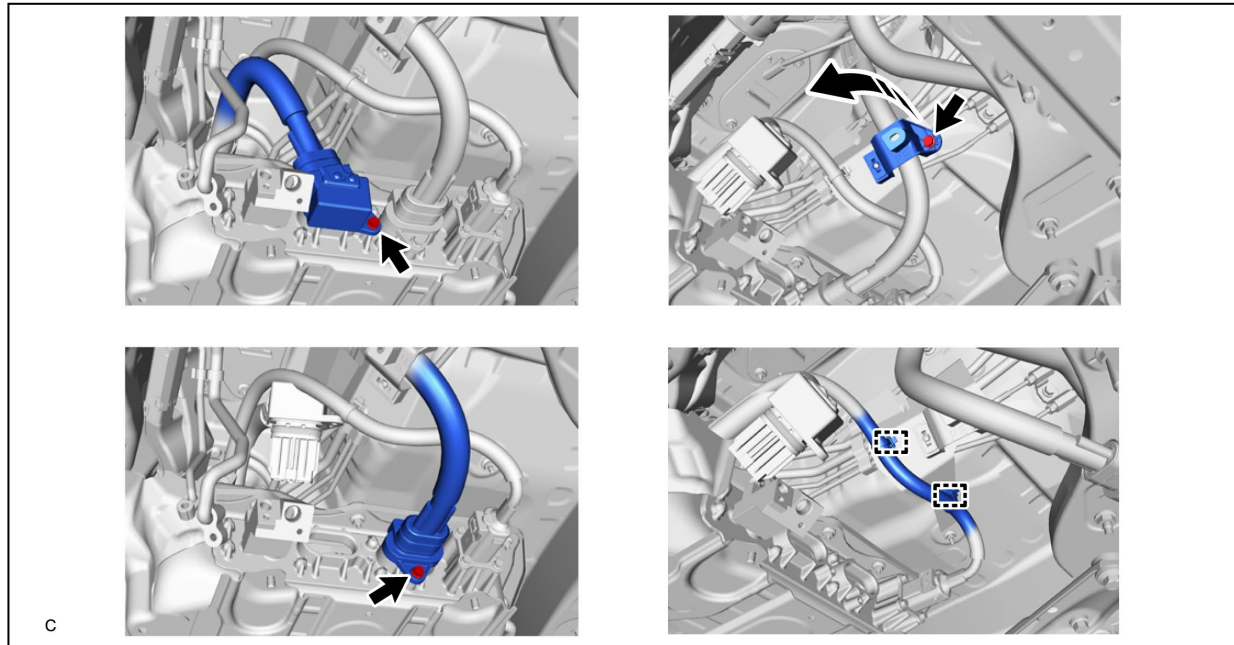

b.

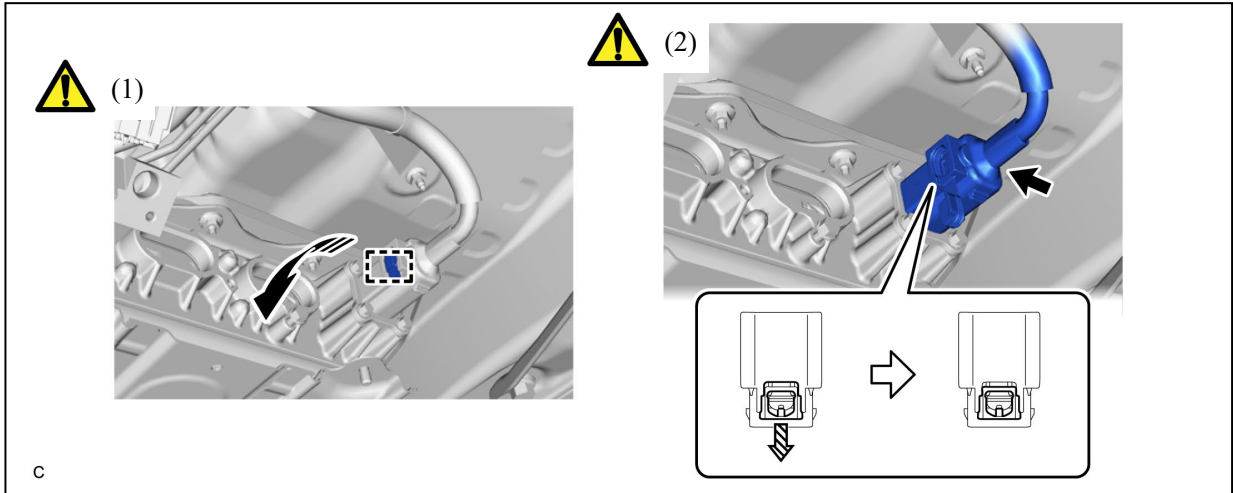

*a	Green-colored Lock	—	—
	Slide	—	—

- (1) Disengage the rubber cap and slide it as shown in the illustration.
- (2) Using a screwdriver, slide the green-colored lock of the connector as shown in the illustration to release it and disconnect the HV floor under wire.

25. DISCONNECT NO. 2 TRACTION BATTERY WIRE

	<p>CAUTION: Be sure to wear insulated gloves and protective goggles.</p> <p>NOTICE: Insulate the disconnected terminals and connector with insulating tape.</p>
--	---

a.

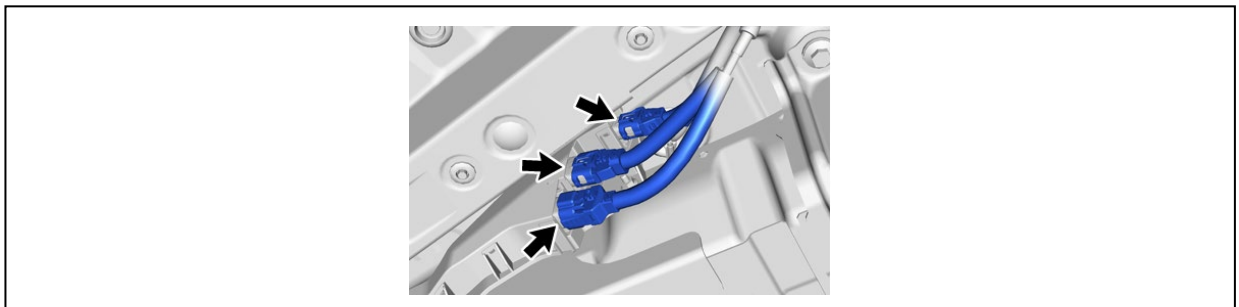

26. REMOVE HV SUPPLY BATTERY ASSEMBLY

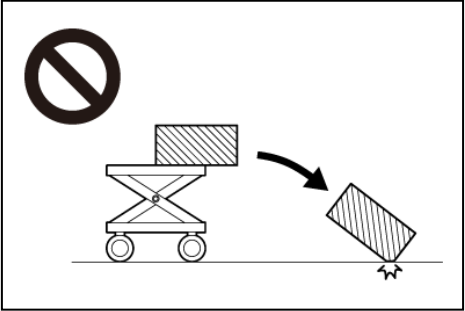
	<p>CAUTION:</p> <ul style="list-style-type: none"> • Because the weight of the HV supply battery assembly is extremely heavy, make sure to follow the work procedures described in the repair manual. • If work is not performed according to the procedures described in the repair manual, there is a danger that the components could fall down. • Do not damage the HV supply battery assembly with the fork etc. • Be sure to wear insulated gloves and protective goggles. 	
---	---	--

a.

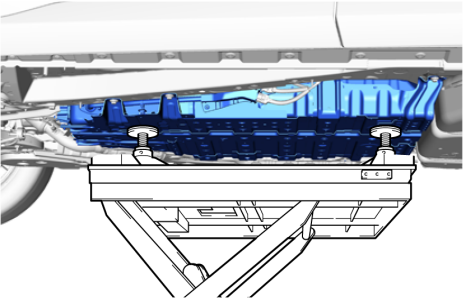
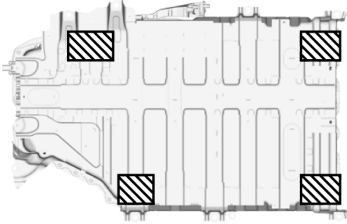
	<p>(1)</p>		
c			

	Area That Can Touch The Ground	—	—
---	--------------------------------	---	---

- (1) Using an engine lifter and 4 attachments or equivalent tools, support the HV supply battery assembly as shown in the illustration.

NOTICE:

- Do not allow foreign matter, such as grease or oil, to adhere to the bolts of the HV supply battery assembly.
- To prevent the wire harness from being caught, make sure to bundle the wire harness using insulating tape or equivalent.
- Since the HV supply battery assembly is very heavy, 2 people are needed to remove it. When removing the HV supply battery assembly, be careful not to damage the parts around it.
- When removing/installing/moving the HV supply battery assembly, make sure not to tilt it more than 80°.
- Do not apply any load outside of the area that can touch the ground.

b.

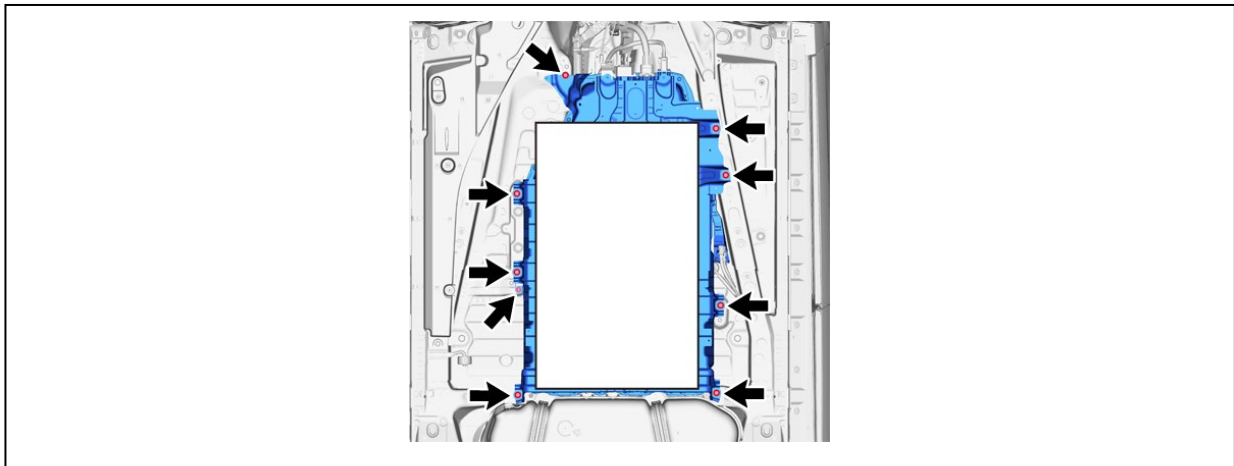

c.

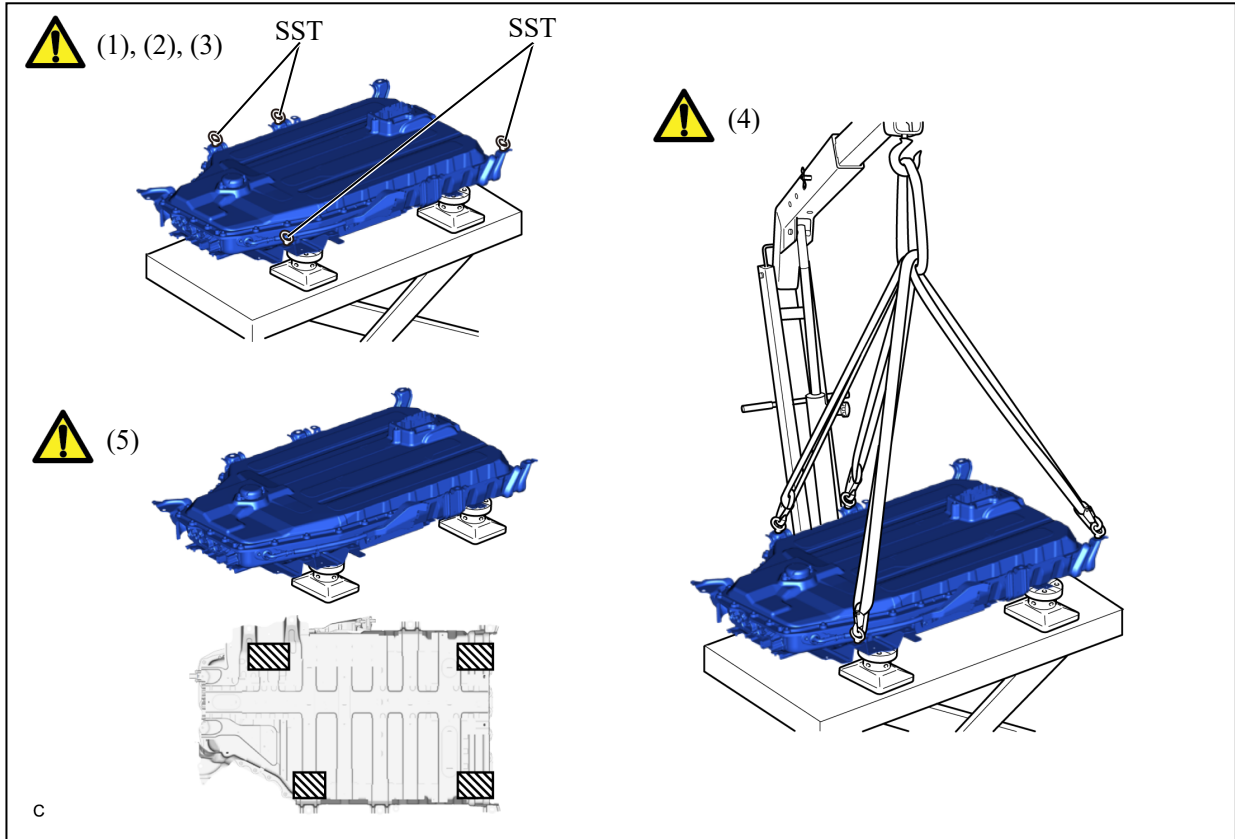

	Area That Can Touch The Ground	—	—
---	--------------------------------	---	---

(1) Slowly lower the engine lifter to remove the HV supply battery assembly.

NOTICE:

Be careful not to drop the HV supply battery assembly.

(2) Follow the procedure below when moving the HV supply battery assembly from the engine lifter.

(3) Install the SST at the position shown in the illustration.

SST: 09893-42010

(4) Using 4 hooks, 4 belt slings and a chain block, hoist the HV supply battery assembly.

NOTICE:

When removing/installing/moving the HV supply battery assembly, make sure not to tilt it more than 80°.

(5) Using the height adjustable attachment, set so that the HV supply battery assembly is in contact with the position shown in the illustration, and place the HV supply battery assembly on the height adjustable attachment.

NOTICE:

- To prevent the wire harness from being caught, make sure to bundle the wire harness using insulating tape or equivalent.
- When removing/moving the HV supply battery assembly, make sure not to tilt it more than 80°.
- Do not apply any load outside of the area that can touch the ground.
- Do not place the lower surface of the battery on the ground.