

# TOWING HITCH DETACHABLE INSTALLATION INSTRUCTIONS NX

Model year: 2014/07  
Vehicle code: AGZ1\*\*-AW\*\*\*W / AYZ15\*-AW\*\*\*W  
Part number: PZ408-X2550-00  
Weight: 46 kg

# Revision Record

Rev. No.	Date	Page	Picture	Update	New	Deleted Steps
1	11-08-2014	20	2	x		
2	05-01-2015	cover; 45	cover; Italian sheet	Vehicle code		
3	23-02-2016	29	13	13		

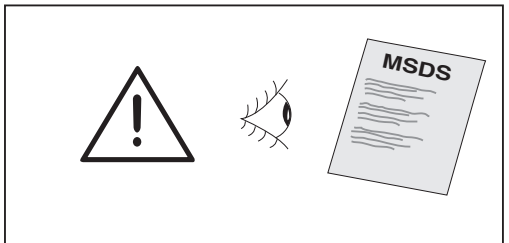
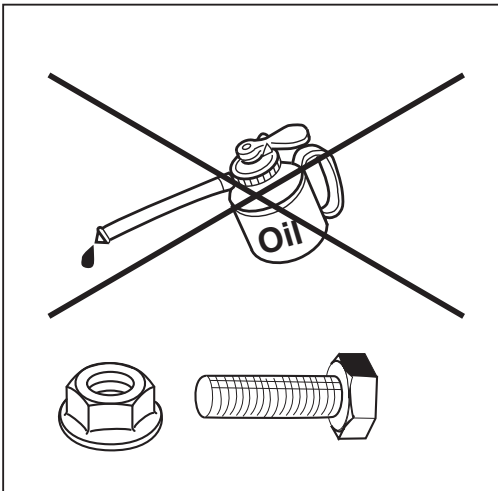

556975/05-06-2014

**GB****FITTING INSTRUCTIONS -  
TOWBAR**

Type: 5569  
 D-value: 9,6 kN  
 Vertical coupling load towbar: 60 kg  
 Manufacturer: Thule B. V.  
 Postbox 24  
 NL 7950 AA Staphorst

Model Application: Lexus NX  
 EC-Type Approval No.: E11 55R 019847

A50-X

**Expert Fitment Required  
Ensure that this fitting instructions is  
passed to the customer**

In order to use the trailer hitch, simultaneous installation of an electrical kit is required. **(Cable set not included!)**

Remove undersealing, anti-corrosion wax and noise-deadening material in the area of the contact surfaces.

Apply corrosion protection material as specified in the LEXUS service guidelines, where necessary.

After approximately 1000 km of trailer use, retighten all bolts to the correct torque values.

For correct trailer loads please refer to vehicle documents of the individual vehicle model.

The coupling ball must be kept clean and well greased\*.

\*EXCEPTION: When stabilizers are used, proceed according to the instructions of the manufacturers of the stabilizer. In this case coupling ball must be inspected for wear at regular intervals.

The trailer coupling must be installed and inspected in accordance with the applicable national regulations.

**D****ANBAUANWEISUNG FÜR  
ANHÄNGEVORRICHTUNG**

Typ: 5569  
 D-Wert: 9,6 kN  
 Stützlast Anhängervorrichtung: 60 kg  
 Hersteller: Thule B. V.  
 Postbox 24  
 NL 7950 AA Staphorst

Verwendungsbereich: Lexus NX  
 EWG-Typgenehmigung Nr.: E11 55R 019847

A50-X

**Einbau von einer Fachwerkstatt durchführen  
lassen.****Diese Einbauanweisung ist dem Kunden aus-  
zuhändigen.**

Zum Betreiben der Anhängervorrichtung ist der gleichzeitige Einbau eines Elektrobausatzes erforderlich. **(Kabelset nicht mitgeliefert!)**

Im Bereich der Anlageflächen muß Unterbodenschutz, Hohlraumkonservierung (Wachs) und Antiröhrnmaterial entfernt werden.

Wo erforderlich, Korrosionsschutz entsprechend den LEXUS-Service Richtlinien vornehmen.

Nach 1000 km Anhängerbetrieb alle Befestigungsschrauben mit vorgeschriebenem Drehmoment nachziehen.

Die für das jeweilige Fahrzeugmodell verbindlichen Anhängelasten sind den Fahrzeugpapieren zu entnehmen.

Die Kupplungskugel ist sauber zu halten und zu fetten\*.

\*AUSNAHME: Bei Verwendung von Stabilisierungseinrichtungen nach den Anweisungen des Herstellers der Stabilisierungseinrichtung vorgehen. Ebenfalls muß bei Verwendung einer solchen Stabilisierungseinrichtung die Kupplungskugel in regelmäßigen Abständen auf Verschleiß untersucht werden.

Der Anbau hat nach dieser Anbauanweisung zu erfolgen und ist gem. §§ 19, 20 oder 21 StVZO durch einen amtlich anerkannten Prüfer oder Sachverständigen zu überprüfen. Die Typgenehmigung der Anhängervorrichtung und diese Anbauanweisung sind dabei vorzulegen. Anbau, Überprüfung und Genehmigung der Anhängervorrichtung müssen den gültigen gesetzlichen Bestimmungen entsprechend durchgeführt werden.

**D**

Der grundsätzliche Anbau der Anhängervorrichtung nach Anhang I, Nr. 5.10 in Verbindung mit Anhang VII der Richtlinie 94/20/EG ist überprüft:

- \* Die vom Fahrzeughersteller serienmäßig genehmigten Befestigungspunkte sind eingehalten.
- \* Die Vorgaben zum Freiraum um die Kugel beziehungsweise über der Kugel sowie zur erforderlichen Höhe der Kugel über der Fahrbahn (Anhang VII, Abbildung 30 der Richtlinie 94/20/EG) sind beim serienmäßigen Fahrzeug gewährleistet.
- \* Die Kenndaten D-Wert und zul. statische Stützlast der Anhängervorrichtung sowie das amtliche Prüfzeichen befinden sich auf dem Typschild.
- \* Nur im Anhängetrieb darf das rückwärtige amtliche Kennzeichen durch die Kugel verdeckt werden, ansonsten ist sie abzunehmen und im Kofferraum befestigt mitzuführen.

**Diese Montage- und Betriebsanleitung ist im Fahrzeug mitzuführen und ggf. berechtigten Personen vorzulegen.**

Der Eintrag dieser EG-geprüften Anhängervorrichtung in die Fahrzeug-Papiere ist nicht (mehr) erforderlich; allerdings wird insbesondere bei Selbstmontage empfohlen, das Fahrzeug nach dem ordnungsgemäßen Anbau der Anhängervorrichtung bei einer auf den Anbau von BRINK Anhängervorrichtungen geschulten Fachwerkstätte vorzuführen, damit die Einhaltung aller Bedingungen nochmals überprüft wird.

#### **Montagehinweise:**

Die Anhängervorrichtung ist ein Sicherheitsteil. Deshalb darf sie nur sach- und fachgerecht montiert werden.

Jegliche Änderungen bzw. Umbauten an der Anhängervorrichtung sind verboten. Sie führen zum Erlöschen der Genehmigung.

Isoliermasse bzw. Unterbodenschutz am Fahrzeug -falls vorhanden -im Bereich der Anlageflächen der Anhängervorrichtung sind zu entfernen. Blanke Karosseriestellen sowie Bohrungen mit Rostschutz versiegeln.

Falls erforderlich, Korrosionsschutz entsprechend den Lexus-Service-Richtlinien vornehmen.

#### **Betriebshinweise:**

Sämtliche Befestigungsschrauben der Anhänge-

**D**

vorrichtung sind nach circa 1000 Anhänger - km mit den vorgeschriebenen Anzugsdrehmomenten nachziehen.

Die Kupplungskugel ist sauber zu halten und leicht zu fetten. Die Verwendung einer Schutzkappe wird empfohlen. Werden jedoch Stabilisierungseinrichtungen verwendet, muß die Kupplungskugel fettfrei sein. Die Hinweise in den diesbezüglichen Betriebsanleitungen sind zu beachten.

Sobald an einer beliebigen Stelle ein Kupplungskugel-Durchmesser von 49,0 mm oder kleiner erreicht ist, darf die Kugel der Anhängervorrichtung aus Sicherheitsgründen nicht mehr weiter benutzt werden.

Das Leergewicht des Fahrzeuges erhöht sich nach Montage der Anhängervorrichtung um circa 46 kg.

Die zulässige Anhängelast und statische Stützlast für das Fahrzeug sind zu beachten. Diese Angaben sind in der Bedienungsanleitung des Fahrzeugs und in den Fahrzeug-Papieren vermerkt. Kontrolle: Die auf dem Fabrikschild der Anhängervorrichtung aufgeführten Daten müssen gleich oder größer sein als die vom Fahrzeughersteller genehmigten Daten. Falls sie größer sind, bleiben die vom Fahrzeughersteller genehmigten Daten gültig.

**E****INSTRUCCIONES DE MONTAJE  
PARA EL DISPOSITIVO DE  
REMOLQUE**

Tipo: 5569  
 Valor-D: 9,6 kN  
 Carga de apoyo de remolque: 60 kg  
 Fabricante: Thule B. V.  
 Postbox 24  
 NL 7950 AA Staphorst  
 Lexus NX  
 E11 55R 019847

Campo de aplicación:  
 la CEE n°: Lexus NX  
 E11 55R 019847

A50-X

**El montaje deberá ser realizado por un taller especializado****Estas instrucciones de montaje deben de ser entregadas al cliente.**

Para el funcionamiento del dispositivo de remolque hace falta al mismo tiempo el montaje de un conjunto eléctrico. **(juego de cables no viene incluido!)**

En el área de las superficies de apoyo han de eliminarse la protección del fondo, la conservación del espacio hueco (cera) y el material antiresonante.

En caso de necesidad, efectuar la protección anticorrosiva de acuerdo con las directrices de servicio de LEXUS.

Al cabo de 1.000 km. de funcionamiento de remolque, reapretar todos los tornillos de fijación con el par de fuerzas especificado.

Las cargas de remolque admisibles para cada modelo respectivo de vehículo se pueden ver en la documentación del mismo.

La bola de acoplamiento ha de mantenerse limpia y engrasarse\*.

\* EXCEPCIÓN: En caso de utilización de dispositivos de estabilización, deberá procederse de acuerdo con las instrucciones del fabricante del dispositivo de estabilización. Igualmente, al utilizar tal dispositivo de estabilización, la bola de acoplamiento ha de examinarse a intervalos regulares en cuanto a su desgaste.

El montaje, la comprobación y la autorización del dispositivo de remolque deberán efectuarse de acuerdo con las disposiciones legales válidas.

**F****NOTICE DE MONTAGE  
DE L'ATTELAGE**

Type: 5569  
 Valeur D: 9,6 kN  
 Charge d'appui de l'attelage: 60 kg  
 Fabricant: Thule B. V.  
 Postbox 24  
 NL 7950 AA Staphorst  
 Lexus NX

Domaine d'utilisation:  
 N° d'homologation de  
 la CE: E11 55R 019847

A50-X

**Confier le montage à un atelier spécialisé****Cette notice de montage doit être remise au client.**

L'utilisation du dispositif de remorquage implique le montage simultané d'un set électrique.  
**(Faisceau de câbles non fourni !)**

La protection du dessous de caisse, la cire de conservation des corps creux et le produit d'insonorisation doivent être enlevés.

Procéder à la protection contre la corrosion là où nécessaire et conformément aux directives de LEXUS-Service.

Après avoir tracté une remorque sur 1000 km resserrer toutes les vis de fixation au couple prescrit.

Les charges pouvant être tractées par chacun des modèles sont prescrites dans les papiers du véhicule.

La rotule doit toujours être propre et graissée.\*

\* EXCEPTION: En cas d'utilisation de dispositifs de stabilisation, procéder selon les instructions du fabricant du dispositif de stabilisation. La rotule doit également être périodiquement vérifiée quant à son usure éventuelle si un tel dispositif de stabilisation est employé.

Le dispositif de remorquage doit être monté, vérifié et autorisé conformément aux dispositions légales en vigueur.

**I****ISTRUZIONE DI MONTAGGIO DEL DISPOSITIVO DI TRAINO**

Tipo: 5569  
 Valore-D: 9,6 kN  
 Carico del timone di traino: 60 kg  
 Produttore: Thule B. V.  
 Postbox 24  
 NL 7950 AA Staphorst  
 Lexus NX  
 Campo d'uso: Lexus NX  
 EURO approval No.: E11 55R 019847

A50-X

**Il montaggio dev'essere affidato a un'officina specializzata.****Le presenti istruzioni di montaggio devono essere consegnate al cliente.**

Per l'utilizzazione del dispositivo di traino è necessaria l'applicazione di un relativo impianto elettrico. **(Set di cavi non in dotazione!)**

Allontanare la protezione sottoscocca, il trattamento antiruggine dei recessi irraggiungibili (cera) e la massa antirombo nell'ambito delle superfici di contatto.

Se e dove necessario applicare la protezione anti-corrosione attenendosi alle direttive service LEXUS.

Dopo 1000 km di uso del traino, stringere di nuovo tutte le viti di fissaggio con il momento torcente prescritto.

Il peso massimo trainabile vincolante per il rispettivo modello di veicolo trainante è riportato nella rispettiva documentazione tecnica del veicolo.

L'aggancio a sfera dev'essere mantenuto pulito e ingrassato (\*).

(\* ECCEZIONE: Nel caso vengano impiegati dispositivi di stabilizzazione attenersi alle istruzioni del produttore del dispositivo di stabilizzazione. Nel caso d'impiego di un tale dispositivo di stabilizzazione è pure necessario di controllare a regolari intervalli di tempo il grado di usura dell'aggancio a sfera.

Il montaggio, la revisione ed il collaudo del dispositivo di traino dovranno essere eseguiti nel rispetto della normativa legale vigente.

**P****INSTRUÇÕES DE MONTAGEM PARA DISPOSITIVO DE REBOQUE**

Tipo: 5569  
 Valor D: 9,6 kN  
 Capacidade de carga de reboque: 60 kg  
 Fabricante: Thule B. V.  
 Postbox 24  
 NL 7950 AA Staphorst  
 Lexus NX  
 Campo de utilização: Lexus NX  
 N° de autorização CEE: E11 55R 019847

A50-X

**Mandar efectuar a montagem em uma oficina especializada****Estas instruções de montagem deverão ser entregues ao cliente.**

Para operação deste dispositivo de reboque, é necessário montar um conjunto eléctrico simultaneamente. **(O conjunto de cabos não está incluído!)**

Na superfície do sistema deverá ser removida a protecção inferior da carroçaria, conservante de espaços ociosos (cera) e material anti-ruído.

Efectuar as medidas de protecção anti-corrosiva onde for necessário, de acordo com as directrizes de serviço da LEXUS.

Reapertar todos parafusos de fixação com o binário de aperto prescrito após 1000 km.

As cargas de reboque permitidas autorizadas para cada modelo de veículo podem ser vistas nos documentos do veículo.

A bola do engate de reboque deverá ser mantida limpa e lubrificada\*.

\* EXCEPÇÃO: Utilizar dispositivos estabilizadores de acordo com as instruções de operação dos fabricantes dos dispositivos. Da mesma forma deve-se controlar a bola do engate em intervalos regulares quanto à desgaste no caso de se utilizar tais dispositivos estabilizadores.

A montagem, controle e autorização do dispositivo de reboque deverão ser executados de acordo com as normas legais.

NL

## MONTAGE-INSTRUCTIE VOOR TREKHAAK

Type: 5569  
 D-waarde: 9,6 kN  
 Draaglast trekhaak: 60 kg  
 Fabrikant: Thule B. V.  
 Postbox 24  
 NL 7950 AA Staphorst  
 Lexus NX  
 Toepassingsgebied:  
 EEG-typegoedkeuring nr.: E11 55R 019847

A50-X

**Montage door een erkende garage laten uitvoeren**

**Deze montage-instructie moet aan de klant worden gegeven.**

Om de trekhaak te kunnen gebruiken is montage van een passende kabelset noodzakelijk.  
**(Kabelset niet meegeleverd!)**

Op de contactvlakken de tectyl, conservering van holle ruimten (was) en antidreunmateriaal verwijderen.

Waar nodig corrosiebescherming overeenkomstig de richtlijnen van de LEXUS-service aanbrengen.

Na 1000 km gebruik van de aanhanger alle bevestigingsbouten met het voorgeschreven draaimoment vastdraaien.

De voor het desbetreffende model auto bindend toegestane gewichten van de aanhangwagen staan in het kentekenbewijs vermeld.

De koppelingskogel moet schoon gehouden en ingevet worden\*.

\* UITZONDERING: Bij gebruik van stabilisatie inrichtingen volgens de aanwijzingen van de fabrikant van de stabilisatie-inrichting te werk gaan. Ook moet bij het gebruik van een dergelijke stabilisatie-inrichting de koppelingskogel regelmatig op slijtage worden onderzocht.

Monteren, controleren en goedkeuring van de aanhanginrichting moeten overeenkomstig de geldende wettelijke bepalingen worden uitgevoerd.

DK

## MONTERINGSVEJLEDNING FOR ANHÆNGERTRÆK

Type: 5569  
 D-Værdi: 9,6 kN  
 Støttebelastning anhængertræk: 60 kg  
 Producent: Thule B. V.  
 Postbox 24  
 NL 7950 AA Staphorst  
 Anvendelsesområde: Lexus NX  
 EWG-typegodkendelse nr. E11 55R 019847

A50-X:

**Monteringen skal foretages af et godkendt værksted.**

**Denne monteringsvejledning skal udleveres til kunden.**

For at kunne anvende anhængertrækket kræves samtidig montering af et el-monterings sæt.  
**(Kabel sæt ikke vedlagt!)**

På anlægsfladerne skal undervognsbeskyttelsen, hullumskonserveringen (voks) og lyd dæmpende materialer fjernes.

Korrosionsbeskyttelse foretages iht. retningslinierne fra LEXUS-Service, hvor dette er påkrævet.

Efter 1000 km kørsel med anhængertrækket skal alle fastgørelsesskruer efterspændes med det foreskrevne drejningsmoment.

De påhængslaster, der er tilladt for den pågældende bilmodel, kan ses i bilens papirer.

Koblingskuglen skal holdes ren og indfedtes\*.

\* UNDTAGELSE: Ved anvendelse af stabiliseringsanordninger skal man gå frem i henhold til anvisningerne fra producenten af stabiliseringsanordningen. Ligeledes skal koblingskuglen ved anvendelse af en sådan stabiliseringsanordning jævnligt undersøges for slitage.

Montering, test og godkendelse af anhængertrækket skal gennemføres i overensstemmelse med gældende lovmæssige bestemmelser.

**N****MONTERINGSANVISNING FOR TILHENDERFESTE**

Type:	5569
D-verdi:	9,6 kN
Støttebelastning tilhengerfeste:	60 kg
Produsent:	Thule B. V. Postbox 24 NL 7950 AA Staphorst
Bruksområde:	Lexus NX
EWG-typogodkjenning:	E11 55R 019847

A50-X

**Monteringen må foretas av et fagverksted**  
**Denne monteringsanvisningen må overleveres til kunden.**

For bruk av tilhengerfestet er det nødvendig med samtidig montering av en elektrobyggekomponent. **(Ledningsknippe ikke inkludert!)**

I festeområdet må understellsbehandlingen, hullromskonserveringen (voks) og antistøymaterialet fjernes.

Dersom nødvendig må korrosjonsbeskyttelsen foretas i henhold til LEXUS service-retningslinjer.

Etter 1000 km tilhengerdrift må alle festeskruene skrues fast igjen med foreskrevet dreiemoment.

De tilhengerlastene som gjelder for de respektive kjøretøymodellene finnes i vognkortet.

Kopplingskulan må alltid holdes ren og må smøres inn\*.

\*Unntak: Ved bruk av stabiliseringsinnretninger, må det gås fram etter anvisning fra produsenten av disse. Likeledes må ved bruk av slike stabiliseringsinnretninger kopplingskulan undersøkes med regelmessige mellomrom for slitasje.

Montering, kontroll og tillatelse til tilhengerfestet må gjennomføres i henhold til de gyldige, lovfestede bestemmelsene.

**S****MONTERINGSANVISNING FÖR FÄSTE FÖR KOPPLINGSKULA**

Typ:	5569
D-värde:	9,6 kN
Stöttebelastning för dragkrok:	60 kg
Tillverkare:	Thule B. V. Postbox 24 NL 7950 AA Staphorst
Användningsområde:	Lexus NX
EURO approval No.:	E11 55R 019847

A50-X

**Låt montaget utföras av en bilverkstad.**  
**Denna monteringsanvisning skall överlämnas till kunden.**

För att kunna använda släpvagnskopplingen är det nödvändigt att montera den tillhörande elektriska monteringsplatsen. **(Kabelset inkluderas ej!)**

På anliggningsytorna måste underretningsbehandlingen, hållrumskonservering (vax) och ljudisoleringsmassa avlägsnas.

Där så erfordras skall korrosjonsbeskydd utföras enligt riktlinjerna för LEXUS service.

Etter 1000 km körning med släpvagn skall alla fästsruvar efterdras med foreskrevet åtdragningsmoment.

Den för respektive bilmodell gällande högsta tillåtna släpfordonsvikten framgår av bilens registreringsbevis.

Kopplingskulan skall hållas ren och infettas\*.

\* UNNTAG: Vid användning av stabiliseringsanordningar som verkar på kopplingskulan, skall man följa anvisningarna från tillverkaren av stabiliseringsanordningen. Vid användning av en sådan stabiliseringsanordning måste kopplingskulan regelbundet undersökas med avseende på slitage.

Montering och kontroll av släpvagnskopplingen måste utföras enligt gällande lagstadgade bestämmelser.



SF

## VETOLAITTEEN ASENNUSOHJE

Tyyppi:	5569
D-arvo:	9,6 kN
Vetokoukun suurin vertikaalinen kytkinkuormitus:	60 kg
Valmistaja:	Thule B. V. Postbox 24 NL 7950 AA Staphorst
Käyttöalue:	Lexus NX
EWG-tyyppihyväksyntä nro:	E11 55R 019847

A50-X

**Asennuksen suorittaa merkikorkorjaamo**

**Tämä asennusohje annetaan asiakkaalle.**

Vetolaitteen käyttöä varten on tarpeen asentaa samanaikaisesti sähkösarja. **(Kaapeliseti ei kuulu toimitukseen!)**

Asennuskohdista on poistettava pohjamaalaus, tyhjän tilan säilöntä (vaha) ja melunestoaine.

Korroosiosuojaa käytetään tarvittavissa kohdin LEXUS huollon antamien ohjeiden mukaan.

Kiristä kaikki kiinnitysruuvit määrättyllä vääntömomentilla, kun vetokoukku on ollut käytössä 1000 km.

Jokaisen ajoneuvomallin sitovat sallitut vetokoukumat on ilmoitettu ajoneuvon papereissa.

Kytkimen nuppi on pidettävä puhtaana ja rasvattavana.\*

\* POIKKEUS: Käytettäessä vakauslaitteita menettellään vakauslaitteen valmistajan antamien ohjeiden mukaan. Samoin on käytettäessä vakauslaitetta tarkastettava kytkimen nupin kulumisen säännöllisin väliajoin.

Vetolaitteen asennus, tarkastus ja hyväksyntä on tehtävä voimassa olevien lakien ja säännösten mukaan.

CZ

## INSTRUKCE K MONTÁŽI ZÁVĚSNÉHO

Typ:	5569
Hodnota D:	9,6 kN
Maximální vertikální spojovací zatížení záchytného háku:	60 kg
Výrobce:	Thule B. V. Postbox 24 NL 7950 AA Staphorst
Oblast použití:	Lexus NX
Čís. povolení typu EHS:	E11 55R 019847

A50-X

**Nechte montáž provést ve specializované dílně**

**Tuto montážní instrukci je třeba předat zákazníkovi.**

Pro provoz závěsného zařízení je zapotřebí současná instalace montážní soupravy elektro. **(Sada kabelů se nedodává společně s výrobkem!)**

V oblasti ploch zařízení je třeba odstranit ochranu podvozku proti korozi, konzervaci dutin (vosk) a tlumicí prostředek.

Kde je to zapotřebí, ošetřete ochranným prostředkem proti korozi podle Servisní směrnice LEXUS.

Po 1000 km provozu s přívěsem dotáhněte všechny šrouby předepsaným utahovacím momentem.

Dovolené hmotnosti přívěsu pro příslušný model vozidla jsou uvedeny v dokladech k vozidlu.

Kouli spojky je třeba udržovat v čistotě a mazat jí\*.

\* VÝJIMKA: Při použití stabilizačních zařízení postupujte podle pokynů výrobce stabilizačního zařízení. Rovněž je třeba při použití takového stabilizačního zařízení v pravidelných intervalech kontrolovat opotřebení koule spojky.

Montáž, kontrola a povolení závěsného zařízení musí odpovídat platným zákonným ustanovením.

**H****A LESZERELHETŐ VONTATÓBERENDEZÉS FELSZERELÉSI**

Típus:	5569
D-érték:	9,6 kN
A vontatórúd max. függőleges összekapcsolási terhelése:	
	60 kg
Gyártó:	Thule B. V. Postbox 24 NL 7950 AA Staphorst
Melyik gépjárműhöz:	Lexus NX
EGK-típusengedély száma:	E11 55R 019847

A50-X

**Ezt a munkát csak egy szakműhellyel szabad elvégezni.****Kérjük adja át ezt a felszerelési utasítást a Vevőnek.**

A vontatóberendezés üzemeltetéséhez egy megfelelő elektromos szerelékészletet is be kell építeni. **(A vezetékcsomag nincs a szállítmányban!)**

A felfekvés felületeknél és azok közvetlen környezetében el kell távolítani az alvázvédőréteget, az üzregítőlt konzerválóanyagokat (viaszt) és a berezésgátló borítást.

Ahol szükséges, a felületeket a LEXUS-szervíz előírásainak megfelelő korrózióvédelemmel kell ellátni.

Miután a vontatóberendezéssel és utánfutóval 1000 km-t megtett, az előírt forgatónyomatékkal ismét húzza meg az összes rögzítőcsavart.

A mindenkor gépjárműmodellhez megengedett vontatható maximális súlya a gépjármű forgalmi engedélyében található.

A kuplunggömböt mindig tisztán kell tartani és be kell zsírozni\*.

\* KIVÉTEL: Ha stabilizálóberendezést használ, akkor a stabilizálóberendezést gyártó cég előírásainak megfelelően kell eljárni. Ilyen esetekben a kuplunggömb kopását rendszeres időközönként ellenőrizni kell.

A vontatóberendezés felszerelését, ellenőrzését és engedélyezését az érvényben lévő törvényes előírásoknak megfelelően kell végrehajtani.

**PL****INSTRUKCJA MONTAŻU WYPOSAŻENIA HOLOWNICZEGO**

Typ:	5569
Wartość-D:	9,6 kN
Maksymalne pionowe obciążenie zcza drga holowniczego:	
	60 kg
Producent:	Thule B. V. Postbox 24 NL 7950 AA Staphorst
Zakres stosowania:	Lexus NX
Nr. zezwolenia EWG:	E11 55R 019847

A50-X

**Montaż zlecić specjalistycznemu warsztatowi****Niniejszą instrukcję należy wręczyć klientowi.**

W celu eksploatacji wyposażenia holowniczego, konieczne jest jednoczesne zamontowanie modułu elektrycznego. **(Zestaw kablowy nie jest dołączony!)**

W strefie powierzchni przylegania musi być usunięte zabezpieczenie podłogi, zabezpieczenie przestrzeni wewnętrznych (wosk) oraz materiały wyciszające.

Tam, gdzie to konieczne, wykonać zgodnie z zaleceniami serwisu firmy LEXUS zabezpieczenie antykorozyjne.

Po 1000 km używania przyczepy należy doręcić wszystkie śruby mocujące stosując przy tym rzeźpisany miment dokręcający.

Obowiązujące, dopuszczalne do doczepiania ciężary są podane dla każdego modelu pojazdu w jego dokumentach.

Sprzęg kulowy należy utrzymać w czystości i smarować go.

\*WYJĄTEK: W przypadku używania wyposażenia stabilizującego należy postępować zgodnie ze wskazówkami producenta tego wyposażenia. Także przy używaniu takiego wyposażenia, sprzęg kulowy musi być regularnie poddawany kontroli na stan jego użycia.

Montaż, kontrola i udzielenie zezwolenia dla wyposażenia holowniczego musi być dokonywane zgodnie z ważnymi postanowieniami prawnymi.

GR

**Οδηγίες τοποθέτησης για αφαιρούμενο  
κοτσαδόρο**

**Τύπος:** 5569  
**D - τιμή:** 9,6 kN  
**Μέγ. κατακόρνοφο  
φορτίο ζεύξης μπάρας  
ρμμούλκησης:** 60 kg  
**Φατασκευαστής:** THULE B. V.  
Postbox 24,  
NL 7950 AA Staphorst  
**Τομέας εφαρμογής:** Lexus NX  
**ΕΟΚ-έγκριση τύπου αρ.:** E11 55R 019847

A50-X

**Η τοποθέτηση εκτελείται σε ένα ειδικό  
συνεργείο**

**Οι οδηγίες τοποθέτησης αυτές παραδίδο-  
νται στον πελάτη.**

Για τη λειτουργία του κοτσαδόρου είναι απα-  
ραίτητη η ταυτόχρονη τοποθέτηση ενός κιτ  
ηλεκτρικής τροφοδοσίας. **(Δεν συμπαραδίδε-  
ται σετ καλωδίων!)**

Στην περιοχή των επιφανειών εφαρμογής  
πρέπει να αφαιρεθεί η προστασία σασί, η  
συντήρηση κενών χώρων (κηρός) και το αντι-  
δονητικό υλικό.

Εκεί, όπου είναι απαραίτητο, προστατεύετε  
έναντι διάβρωσης σύμφωνα με τις οδηγίες  
του LEXUS-σέρβις.

Μετά από 1000 χιλιόμετρα διαδρομής με  
ρυμουλκόμενο φορτίο σφίγγετε πάλι όλες τις  
βίδες στερέωσης με την προκαθορισμένη  
ροπή περιστροφής.

Ενημερωθείτε για το επιτρεπόμενο ορτίο  
ρμμούλκησης για το εκάστοτε μοντέλο οχήμα-  
τος από τα χαρτιά του οχήματός σας.

Ο κοτσαδόρος πρέπει να διατηρείται καθαρός  
και να λιπαίνεται\*.

\*ΕΞΑΙΡΕΣΗ: Σε περίπτωση χρήσης διατάξεων  
σταθεροποίησης, οι οποίες δρουν  
επάνω στον κοτσαδόρο, ενεργείτε  
σύμφωνα με τις υποδείξεις του  
κατασκευαστή των διατάξεων  
σταθεροποίησης. Επίσης πρέπει  
σε περίπτωση μιας τέτοιας διάτα-  
ξης σταθεροποίησης ο κοτσαδό-  
ρος να ελέγχεται σε τακτά διαστή-  
ματα για πιθανές φθορές.

Η τοποθέτηση, ο έλεγχος και η χορήγηση άδειας λειτουρ-  
γίας του κοτσαδόρου πρέπει να διεξάγονται σύμφωνα με  
τις ισχύουσες νομοθετικές διατάξεις.

**RUS****ИНСТРУКЦИЯ ПО МОНТАЖУ  
БУКСИРНОГО КРЮКА**

Модель: 5569  
Коэффициент D (определяется по массе автомобиля и прицепа): 9,6 kN  
Вертикальная нагрузка на буксирный крюк: 60 kg  
Производитель: THULE B. V.  
Postbox 24  
NL 7950 AA Staphorst  
Lexus NX

Диапазон использования:  
Номер разрешения по нормам ЕС для данной модели: E11 55R 019847

A50-X

**Монтаж должен выполняться сертифицированной автомастерской.****Настоящая инструкция по монтажу должна предоставляться заказчику.**

Для того чтобы буксирный крюк можно было использовать, необходимо смонтировать соответствующие данной модели провода (**провода в комплект поставки не входят!**)

Удалить текстиль с контактных поверхностей, средства консервации (восковой состав) из полостей и антишумовой материал.

Где необходимо, нанести антикоррозионное покрытие в соответствии с нормами сервиса для моделей LEXUS.

После пробега прицепом 1000 км затянуть все крепящие болты, используя ключ с заданным крутящим моментом.

Допустимая для данной модели автомобиля масса прицепа указана в техническом паспорте автомобиля.  
Сцепной шар должен быть чистым и покрыт смазкой\*.

\* ИСКЛЮЧЕНИЕ: при использовании стабилизирующих приспособлений руководствоваться указаниями производителя данных приспособлений. В случае применения подобных стабилизирующих приспособлений регулярно проверять износ сцепного шара.

Монтаж, контроль и сертификация прицепа должны выполняться в соответствии с действующими законоположениями.

**TR****ÇEKİ DEMİRİ MONTAJ TALİMATLARI**

Tipi: 5569  
D-değeri: 9,6 kN  
Çeki demirinin dikey çekme yükü: 60 kg  
İmalatçı: THULE B. V.  
Postbox 24  
NL 7950 AA Staphorst  
Lexus NX

Uygulama alanı:  
Avrupa Ekonomik Topluluğu (EEG) onay numarası: E11 55R 019847

A50-X

**Montajı onaylı bir oto tamircisinde yaptırın  
Bu montaj talimatları müşteriye veriliyor olmalıdır.**

Çeki demirini kullanmak için uygun kablo takımı olması gereklidir. (**Kablo takımı birlikte verilmmez**)

Temas yüzeylerinde gres, koruyucu katman ve sürtünmeye karşı maddeyi uzaklaştırın.

Gerektiğinde sürtünmeye karşı korumayı LEXUS-servis kurallarıyla uyumlu olarak sürün.

Yaklaşık 1000 km kullandıktan sonra bütün somun ve civataları talimatlara uygun olarak tekrar sıkın.

Her model için geçerli olan çekme ağırlıkları araba ruhsat evrakında belirtilmiştir.

Çeki demiri topuzu temiz tutulmalı ve yağlanmalıdır\*.

\* İSTİSNA: Sabitleme aletlerinin kullanılması durumunda, bu sabitleme aletinin üreticisinin kurallarına göre davranın. Sabitleme aletlerinin kullanılması durumunda da çeki demiri topuzunun düzenli olarak aşınmaya karşı kontrol edilmesi gerekir.

Çeki demiri ve çekme arabasının montaj, kontrol ve muayenesi çekme teçhizatı için geçerli olan yasa kurallarına göre yapılmalıdır.

**BG** Инструкции за монтаж – ТЕГЛИЧ

Тип: 5569  
D-стойност: 9,6kN  
Вертикално свързване  
на товарния теглич: 60 kg  
Производител: THULE B.V  
Postbox 24  
NL 7950 AA Staphorst

Модел на  
приложението: Lexus NX  
ЕС-тип одобрение №: E11 55R 019847

A50-X

**Монтажът трябва да се извърши от специалисти.**

**Направете така, че тези инструкции за монтаж да се предадат на клиента.**

За да използвате прикачното устройство на ремаркетото е необходимо едновременно да монтирате и електрическата инсталация.  
**(Кабели не са включени!)**

Махнете подложения за уплътнение антикорозионен восък и шумоизолиращия материал около контактните повърхности.

Нанесете материал за защита от корозия там, където е необходимо, както е посочено в ръководството за обслужване на LEXUS.

След около 1000 km използване на ремаркетото, затегнете всички болтове до правилните стойности на въртящия момент.

За правилни натоварвания на ремаркетото, моля, вижте документите на превозното средство според индивидуалния модел.

Сферичният шарнир трябва да се пази чист и добре смазан\*.

**\*ИЗКЛЮЧЕНИЕ:** Когато се използват стабилизатори, действайте според инструкциите на производителите на стабилизатора. В този случай сферичният шарнир трябва да се преглежда за износване на определени интервали.

Съединителният механизъм на ремаркетото трябва да се монтира и проверява в съответствие с приложимите национални разпоредби.

**EST** TIISLI PAIGALDUSJUHISED

Tüüp: 5569  
D-väärtus: 9,6 kN  
Vertikaalkoormus  
haakeseadmele: 80kg  
Tootja: THULE B.V  
Postbox 24  
NL 7950 AA Staphorst

Sobiv mudel: Lexus NX

EÜ tüübikinnituse nr: E11 55R 019847

A50-X

**Vajalik on professionaalne paigaldus  
Veenduge, et klient saab paigaldusjuhised  
kätte.**

Haakeseadme kasutamiseks tuleb samaaegselt paigaldada ka elektrikomplekt.  
**(Kaablikomplekt ei kuulu varustusse!)**

Eemaldage kokkupuutepindadelt aluskate, korrosioonivastane vaha ja mürasummutusmaterjal.

Kandke vajalikesse kohtadesse korrosioonikaitse vahendit vastavalt LEXUS hooldusjuhistele.

Pärast ligikaudu 1000 km haagise kasutust, keerake kõik poldid uuesti õigele jõumendile.

Haagisele sobivaid koormusi vaadake palun vastava sõidukimudeli dokumentidest.  
Jälgige, et ühenduspall oleks puhas ja määritud\*.

\*ERAND: Kui kasutate stabilisaatoreid, siis jätkake vastavalt stabilisaatori tootja juhistele. Sellisel juhul peab ühenduspalli regulaarsete ajavahemike tagant kontrolliima.

Haakeseadet tuleb paigaldada ja kontrollida vastavalt kehtivale riiklikele määrustele.

LV

**BUKSĒŠANAS STIĒŅA IEKĀRTAS  
UZSTĀDĪŠANAS INŠTRUKCIJA**

Tips:	5569
Koeficients D (nosaka pēc automobiļa un autopiēkabas masas):	9,6 kN
Vertikālā slodze uz buksēšanas stieņa iekārtas:	60 kg
Ražotājs:	THULE B. V. Postbox 24 NL 7950 AA Staphors Lexus NX
Lietošanas diapazons: Eiropas Kopienas tipa atļauja Nr.:	E11 55R 019847

A50-X

**Buksēšanas stieņa iekārtas uzstādīšana jāveic sertificētam automobiļu mehāniķim. Lūdzu, nodrošiniet šīs uzstādīšanas instrukcijas nodošanu klientam.**

Lai liētu buksēšanas stieņa iekārtu, nepieciešams uzstādīt attiecīgos elektriskos komponentus. **(Vadi komplektā nav iekļauti!)**

Noņemiet no kontakta virsmām nehermētisko blīvējumu, pretkorozijas vasku un trokšņus slāpējošo materiālu.

Ja nepieciešams, apstrādājiet virsmas ar pretkorozijas materiālu, kā norādīts "LEXUS" servisa norādēs.

Pēc aptuveni 1000 km nobraukšanas ar autopiēkabi pārbaudiet, vai visas bultskrūves ir pievilktas līdz pareizajam griezes momentam. Lai iegūtu informāciju par autopiēkabas atļautajām slodzēm, lūdzu, skatiet attiecīgā transportlīdzekļa modeļa dokumentāciju. Savienošanai lodei jābūt tīrai un pietiekami ieeļļotai.\*

**\*PIEZĪME:** lietojot stabilizatorus, rīkojieties saskaņā ar stabilizatora ražotāja instrukciju. Regulāri pārbaudiet, vai savienošā lode nav pārmērīgi nodilusi.

Autopiēkabas savienojums jāizveido un jāpārbauda atbilstoši saistošajiem likuma noteikumiem.

LT

**TVIRTINIMO INSTRUKCIJOS - TEMPIMO  
STRYPAS**

Tips:	5569
D-reikšmē:	9,6 kN
Vertikālais tempimo tempimo juosta:	60 kg
Gamintojas:	THULE B. V. Postbox 24 NL 7950 AA Staphorst Lexus NX
Naudojamas modelis:	EB Tipo patvirtinimo nr.:
	E11 55R 019847

A50-X

**Reikia patyrusio tvirtintojo įsitinkite, kad šios tvirtinimo instrukcijos bus pateikiamos klientui.**

Norint naudotis priekaba, kartu reikia sumontuoti ir elektros rinkinį. **(Kabeliai nepridedami!)**

Nuo kontaktuojančių paviršių nuimkite apatinį sandariklio sluoksnį, antikorozinį vašką ir triukšmą šalinančią medžiagą.

Kur reikia, uždėkite apsaugančią nuo korozijos medžiagą, kaip nurodyta „LEXUS“ priežiūros instrukcijose.

Kai priekaba nuvažiuos maždaug 1000 km, iš naujo tinkamai priveržkite visus varžtus.

Dėl tinkamos priekabos apkrovos žiūrėkite atskirų modelių dokumentus. Jungties rutulys turi būti švarus ir gerai suteptas\*.

**\*ĮŠIMTIS:** jei naudojami stabilizatoriai, laikykitės stabilizatoriaus gamintojo pateiktų instrukcijų. Šiuo atveju reikia reguliariai tikrinti, ar jungties rutulys nesusidėvėjęs.

Priekabos jungtis turi būti montuojama ir apžiūrima pagal galiojančius vietinius reikalavimus.

**RO****INSTRUCȚIUNI DE MONTARE - BARĂ DE TRACTARE**

Tip: 5569  
 Valoare D: 9,6 kN  
 Sarcina barei de tractare  
 la cuplarea verticală: 60 kg  
 Producător: THULE B. V.  
 Postbox 24  
 NL 7950 AA Staphorst  
 Aplicare model: Lexus NX  
 Nr. aprobare tip CE: E11 55R 019847

A50-X

**Este necesară montarea de către un specialist**

**Asigurați-vă că aceste instrucțiuni de montare sunt înmânate clientului.**

Pentru a utiliza cârligul de remorcare, este necesară instalarea simultană a unui kit electric. **(Setul de cabluri nu este inclus!)**

Îndepărtați învelișul de ceară anticorozivă și materialul antifonant în zona suprafețelor de contact.

Unde este necesar aplicați material de protecție anticorozivă după cum este specificat în ghidul de service LEXUS.

După aproximativ 1000 km de utilizare a remorcii, restrângeți toate șuruburile la valorile de cuplu corecte.

Pentru sarcinile de remorcare corecte consultați documentele vehiculului în funcție de model. Bila de cuplare trebuie menținută curată și bine lubrifiată\*.

\*EXCEPȚIE: Când se utilizează stabilizatori, respectați instrucțiunile producătorului acelor stabilizatori. În acest caz bila de cuplare trebuie inspectată pentru uzură la intervale regulate.

Sistemul de cuplare al remorcii trebuie instalat și inspectat în conformitate cu reglementările naționale în vigoare.

**SK****POKYNY PRE MONTÁŽ - ŤAŽNÉ ZARIADENIE**

Typ: 5569  
 Hodnota D: 9,6 kN  
 Maximálne vertikálne  
 zaťaženie ťažného zariadenia: 60 kg  
 Výrobca: THULE B. V.  
 Postbox 24  
 NL 7950 AA Staphorst  
 Použitie na model: Lexus NX  
 Schválenie typu EK č.: E11 55R 019847

A50-X

**Vyžaduje sa montáž odborníkmi**

**Uistite sa, že tieto pokyny pre montáž budú odovzdané zákazníkovi.**

Pre použitie ťažného zariadenia je súčasne potrebná inštalácia elektrickej výbavy. **(súprava káblov nie je súčasťou dodávky!)**

V priestore styčných plôch je potrebné odstrániť tesnenie, protikorozy vnok a materiál na tlenie hluku.

Podľa potreby aplikujte materiál na ochranu pred koroziou tak, ako je uvedené v servisných smerniciach LEXUS.

Približne po 1000 km používania prívesu dotiahnite všetky skrutky na správne hodnoty krútiaceho momentu.

Informácie o povolených hmotnostiach prívesov možno nájsť v dokumentoch k danému modelu vozidla.

Ťažná guľa musí byť udržiavaná v čistote a namazaná vazelínou\*.

\*VÝNIMKA: Ak sa používajú stabilizátory, postupujte podľa pokynov výrobcu stabilizátorov. V takom prípade sa ťažná guľa musí v pravidelných intervaloch kontrolovať na opotrebovanie.

Ťažné zariadenie sa musí namontovať a skontrolovať v súlade s platnými národnými predpismi.

Vrsta:	5569
D-vrednost:	9,6 kN
Spojna sila vlečne kljuge v navpični smeri:	60 kg
Proizvajalec:	THULE B. V. Postbox 24 NL 7950 AA Staphors
Področje uporabe:	Lexus NX
Št. ES-homologacije:	E11 55R 019847

A50-X

**Montažo vlečne kljuge naj opravijo ustrezno usposobljeni serviserji  
Kupec mora prejeti ta navodila za montažo.**

Za uporabo vlečne kljuge morate hkrati vgraditi tudi ustrezno električno instalacijo. **(kabelski komplet ni priložen)**

Na naležnih površinah odstranite talno zaščito, vosek za zaščito proti koroziji in material zvočne izolacije.

Material za zaščito proti koroziji nanesite na predvidena mesta v skladu s LEXUS smernicami za servisiranje.

Po pribl. 1000 prevoženih km s prikolico znova trdno privijte vijake s predpisanim navorom. Podatke o nosilnosti prikolice boste našli v dokumentaciji vozil posameznih modelov. Naležna krogla mora biti čista in zadostno namazana\*.

\*IZJEMA: Če uporabljate stabilizatorje, postopajte v skladu z navodili njihovega proizvajalca. V tem primeru je naležno kroglo treba v rednih časovnih intervalih preverjati glede obrabe.

Vlečno kljuko za vozilo je treba montirati in preveriti v skladu z veljavnimi državnimi predpisi.





A  (2x) M6x20 (10.9)

B  (1x) M6x30 (8.8)

C  (6x) M8x40 (10.9)

D  (10x) M12x1,25x50 (8.8)

E  (6x) M12x60 (10.9)

F  (4x) M12x25 (100)

G  (2x) M6 (10)

H  (6x) M12 (10)

I  (6x) M8

J  (6x) M12

K  (6x) M8

L  (10x) M12

M  (4x) M12

N  (2x) M6

O  (1x)

P  (2x)



(1x)

PZ408-90550-02

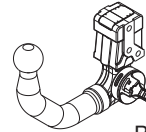

PZ408-X2550-01

PZ408-X2550-60

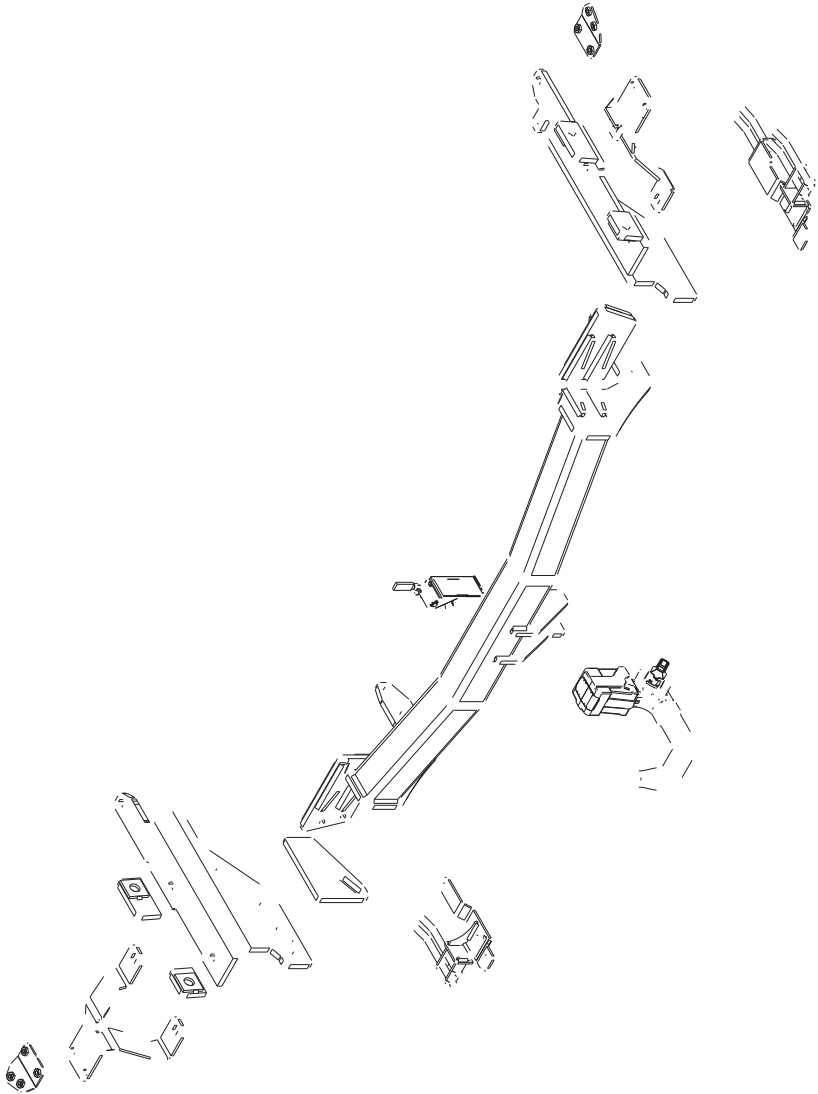

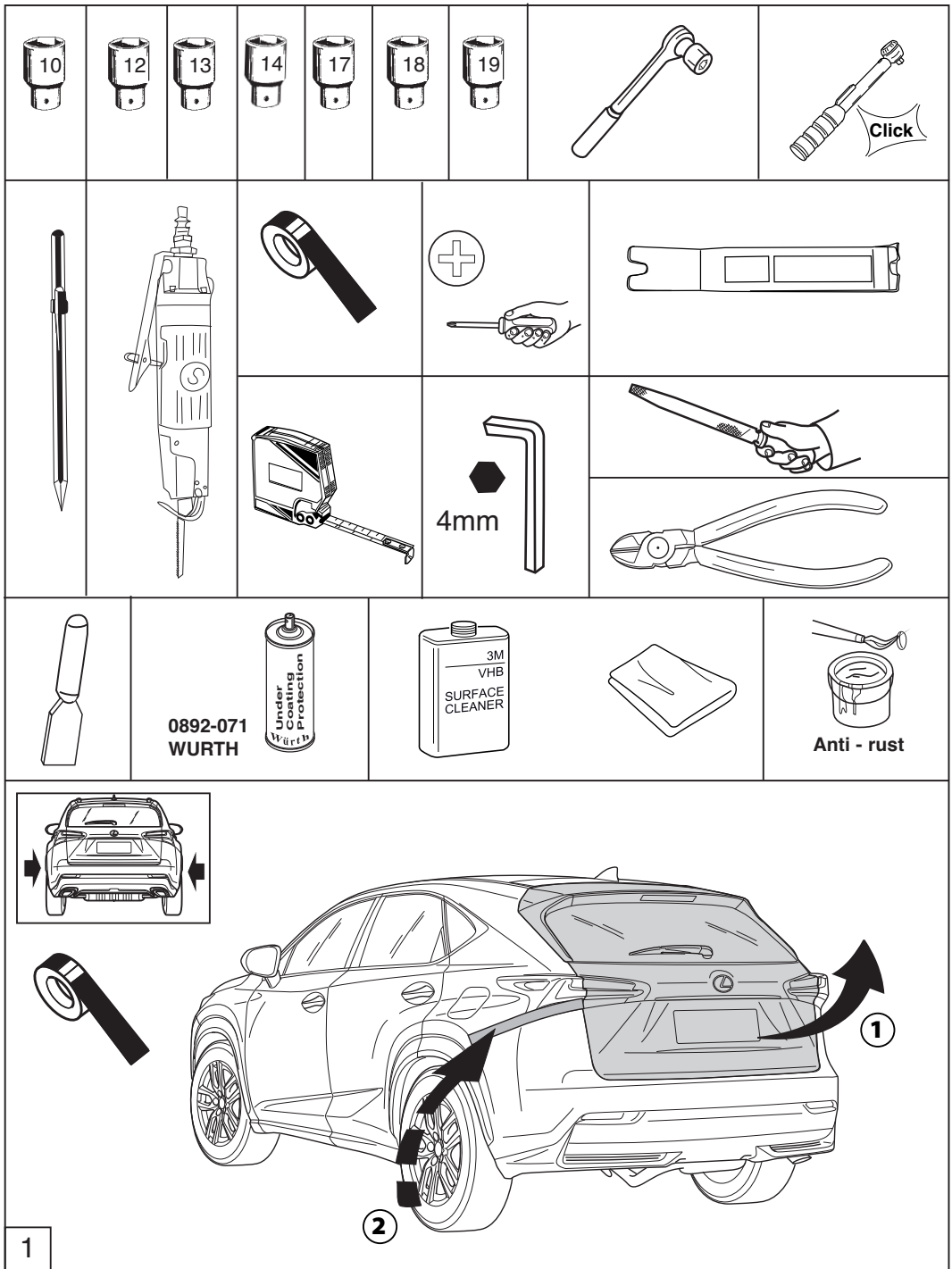

1

2

1

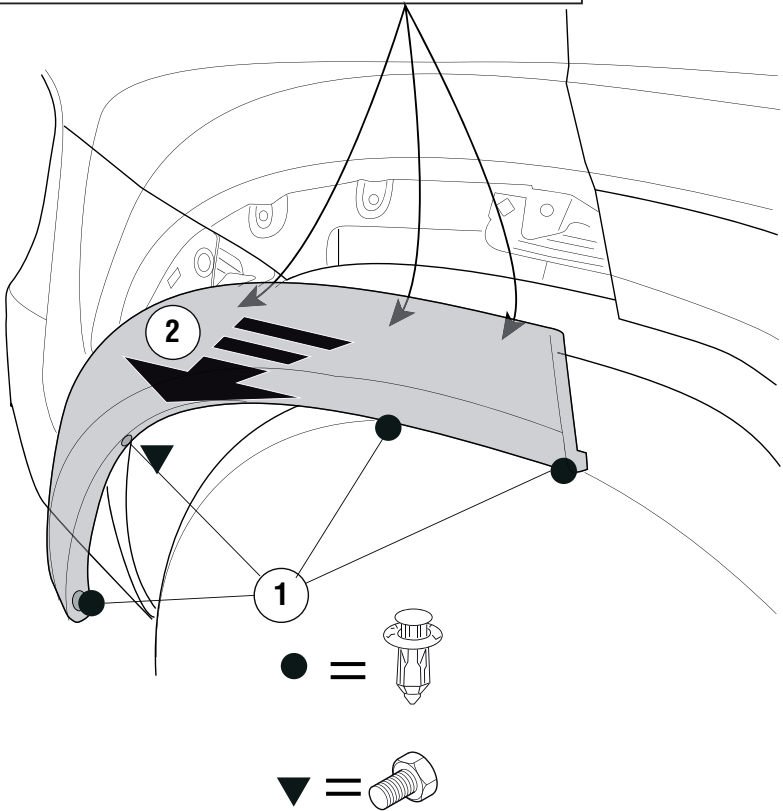
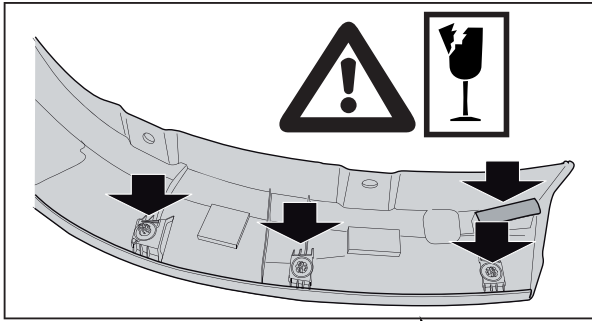
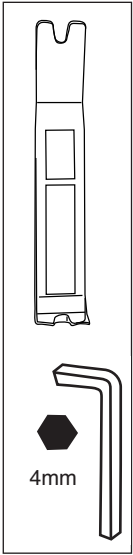
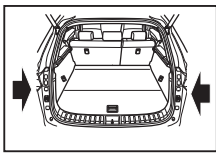

2

## Petrol

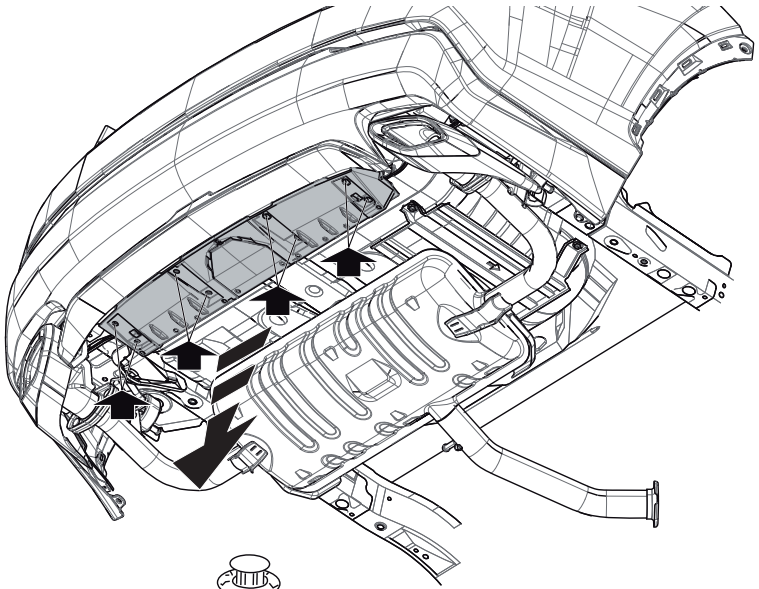
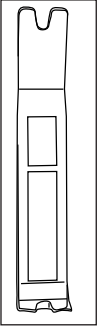

## Hybrid

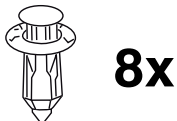
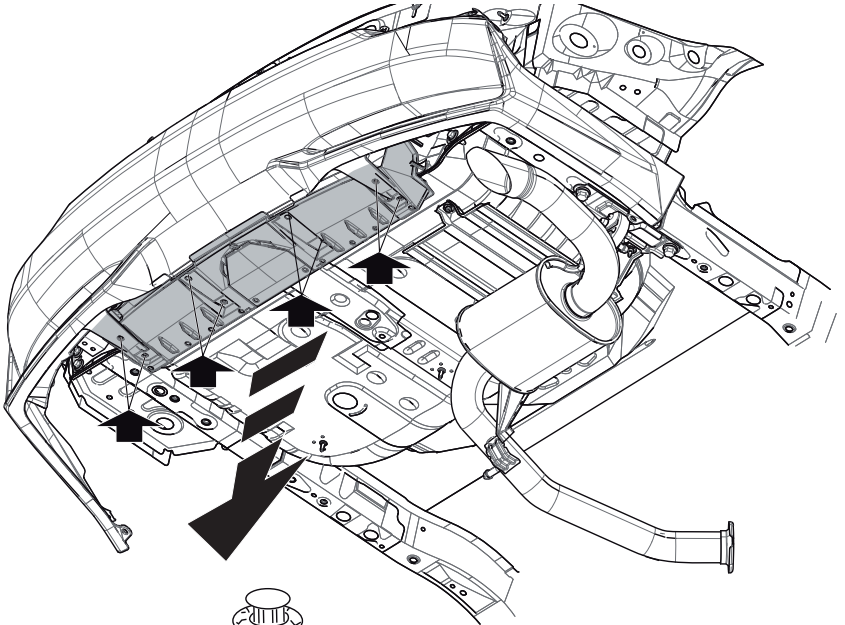

3

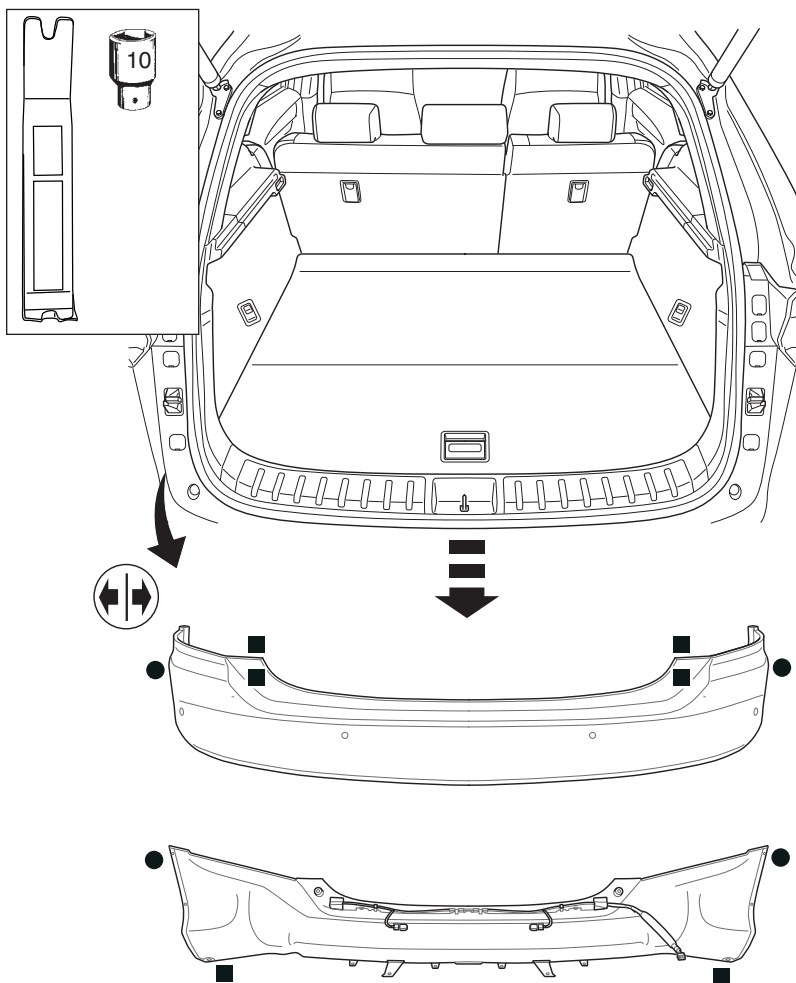
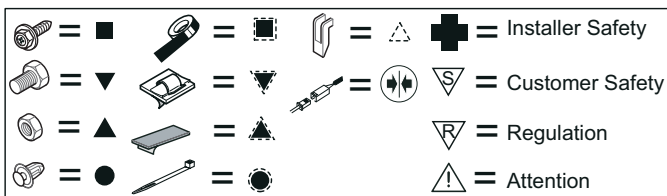

	=			=		=	Installer Safety
	=			=		=	Customer Safety
	=			=		=	Regulation
	=			=		=	Attention

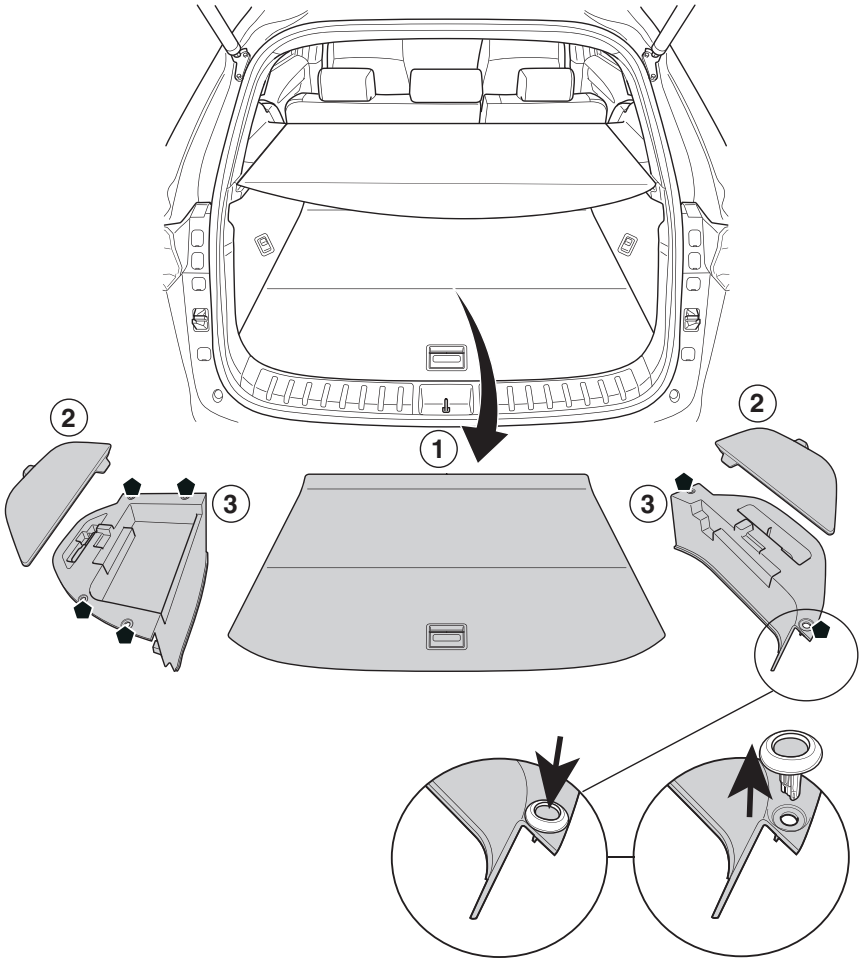

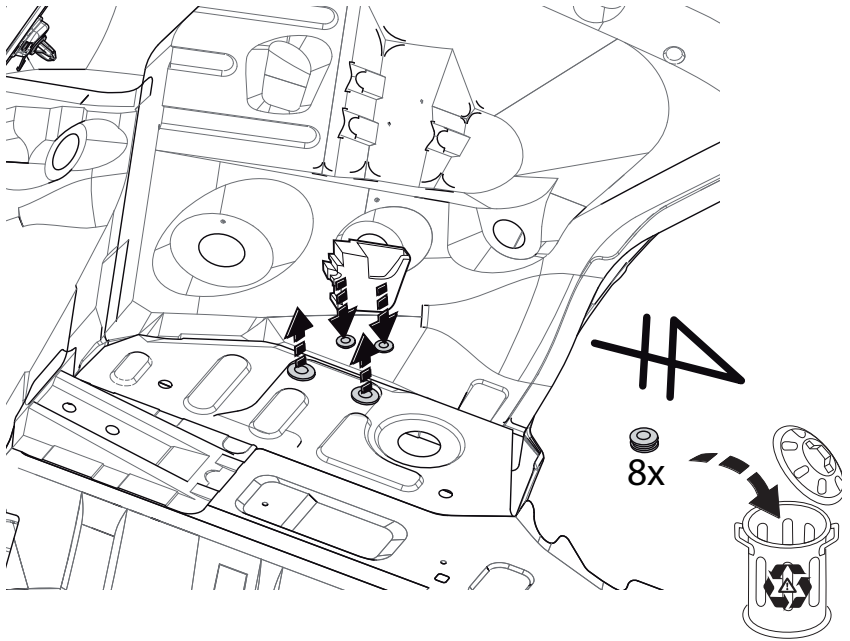
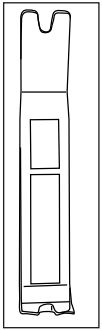
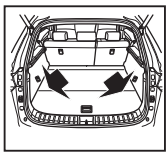

6

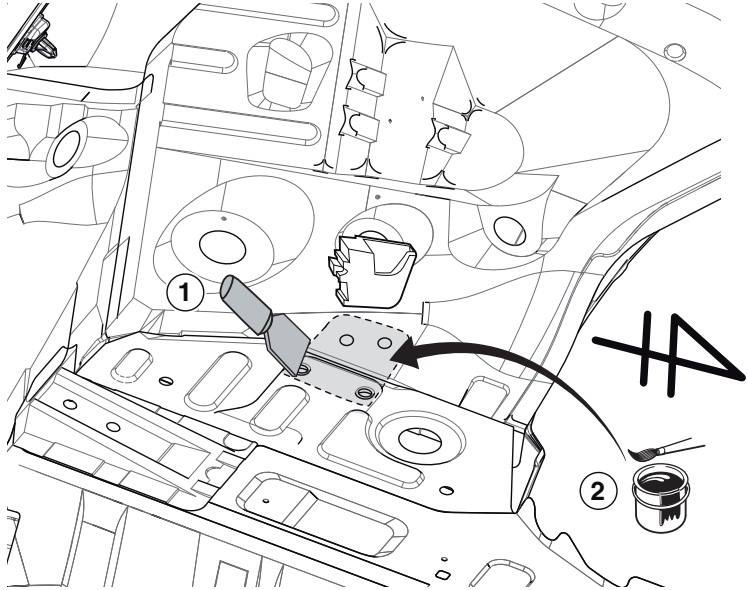
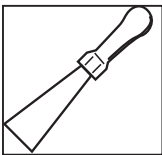
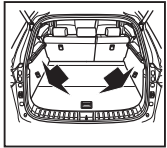

7



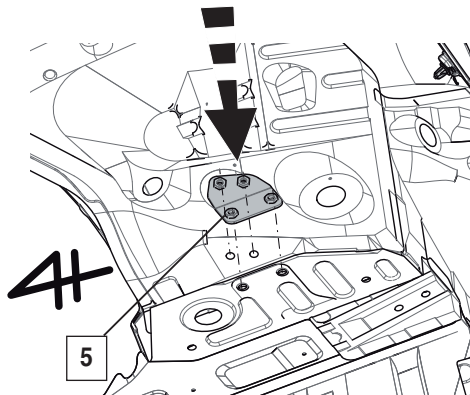
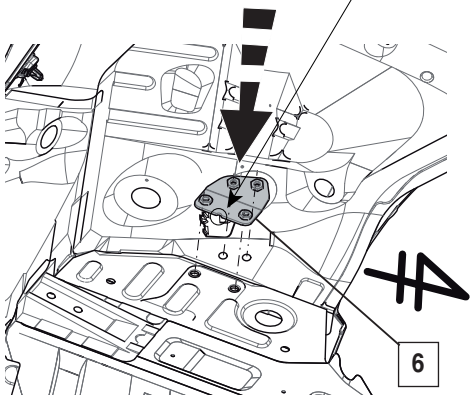
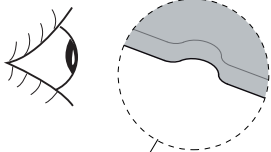
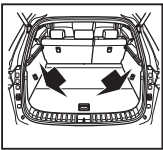

8

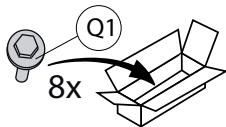
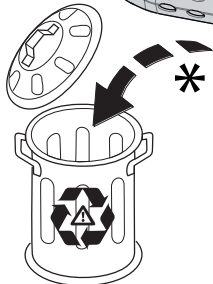
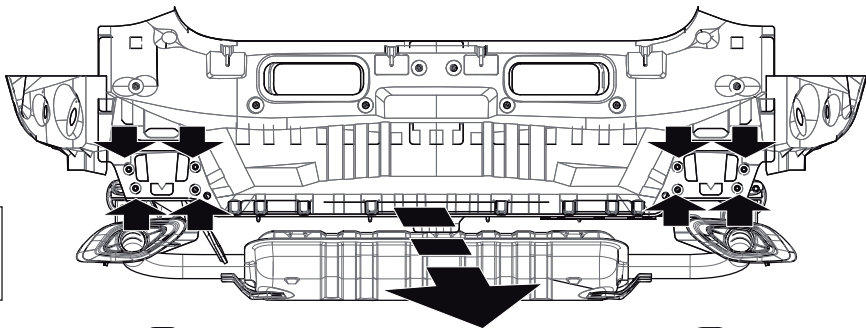

9

## Petrol

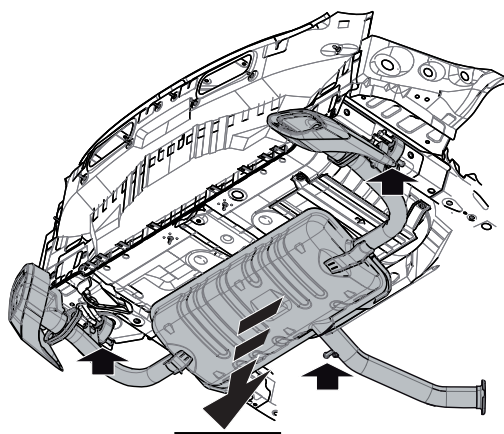

## Hybrid

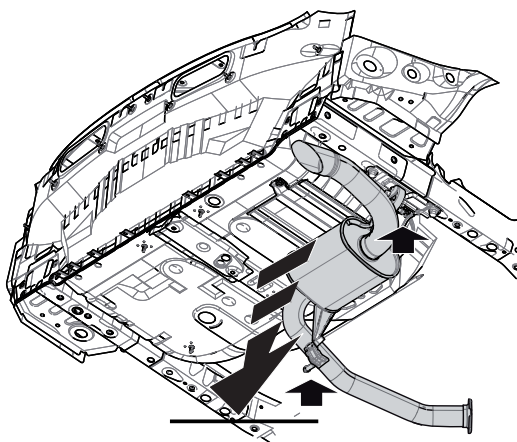

10

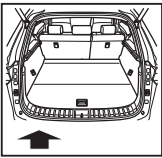

## Petrol

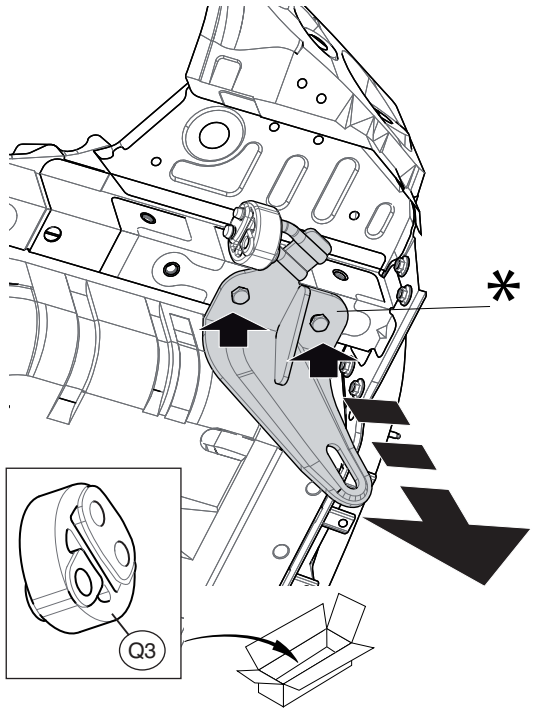
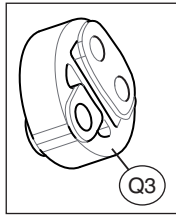
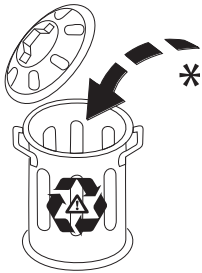

## Hybrid

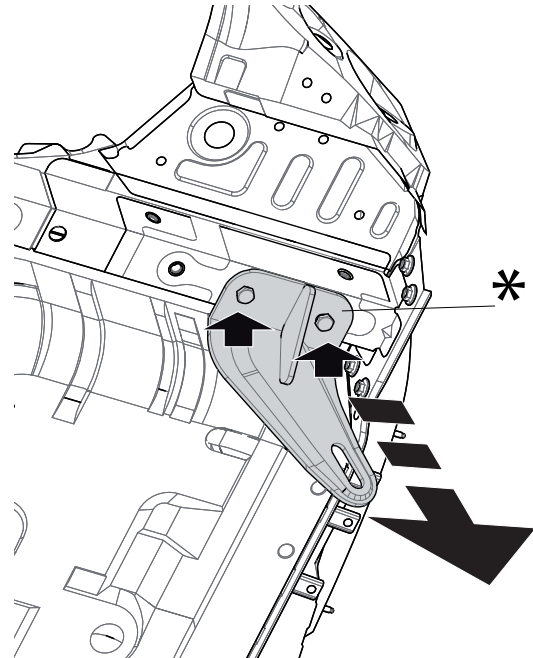
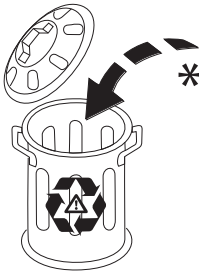

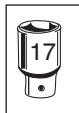
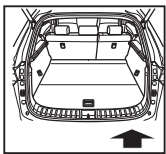

**Petrol**

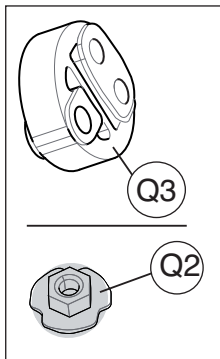
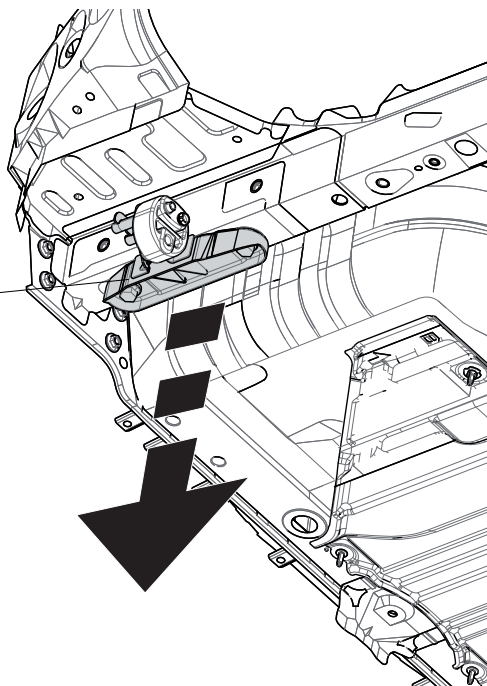

**Hybrid**

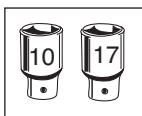
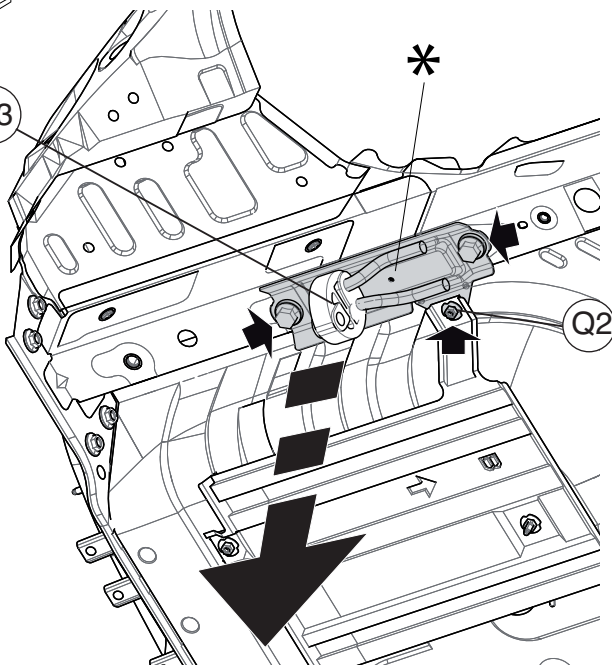

12

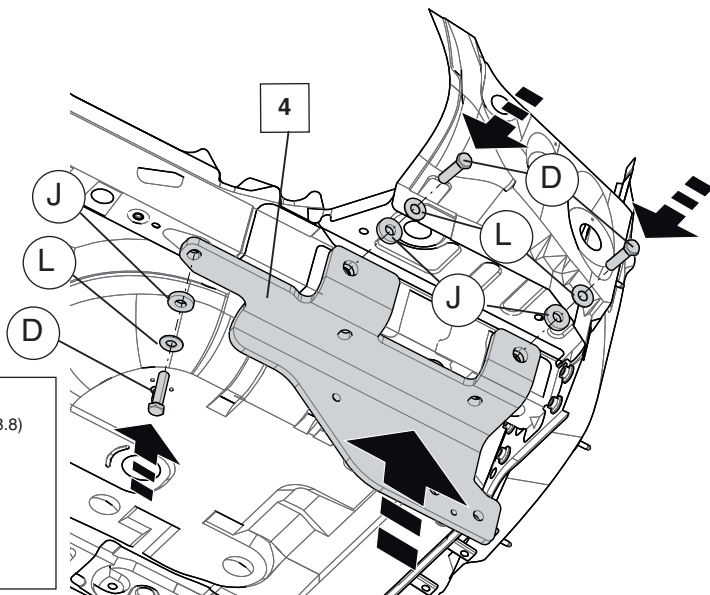
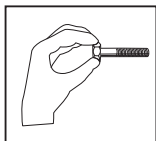
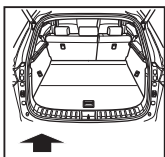

D (3x) M12x1,25x50 (8.8)

L (3x) M12

J (3x) M12

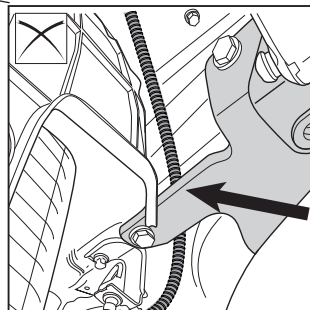
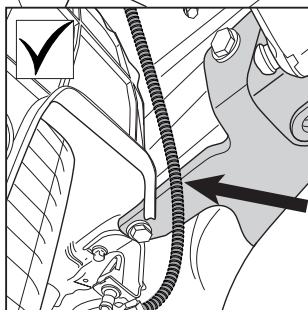
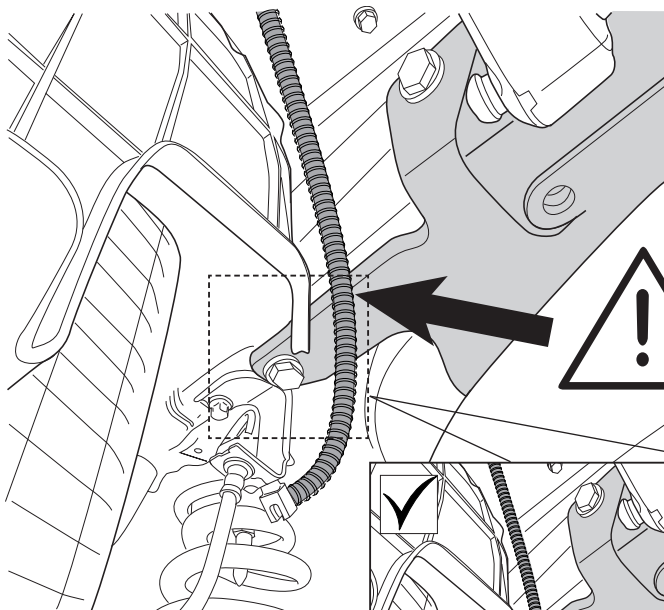

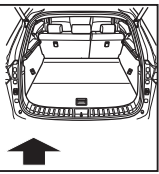

13

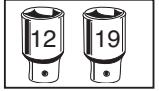
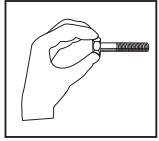

# Hybrid



- D**  (2x) M12x1,25x50 (8.8)
- L**  (2x) M12

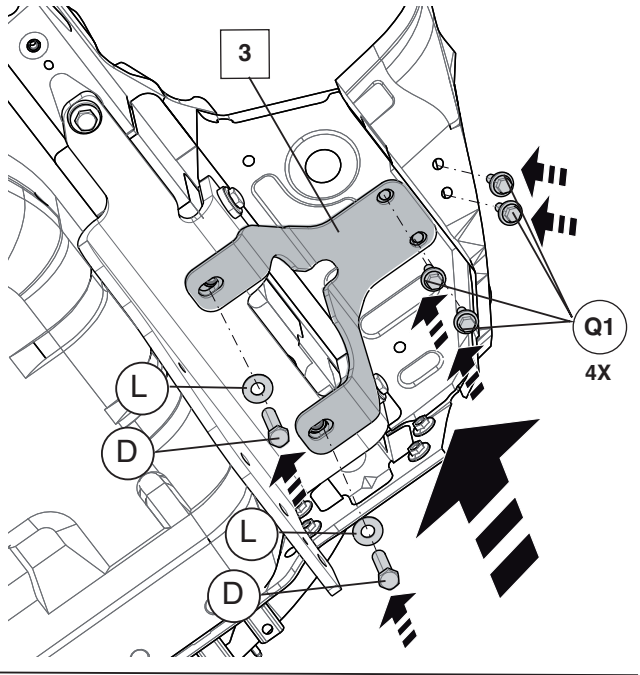
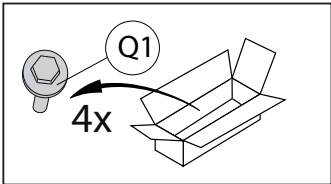

# Petrol

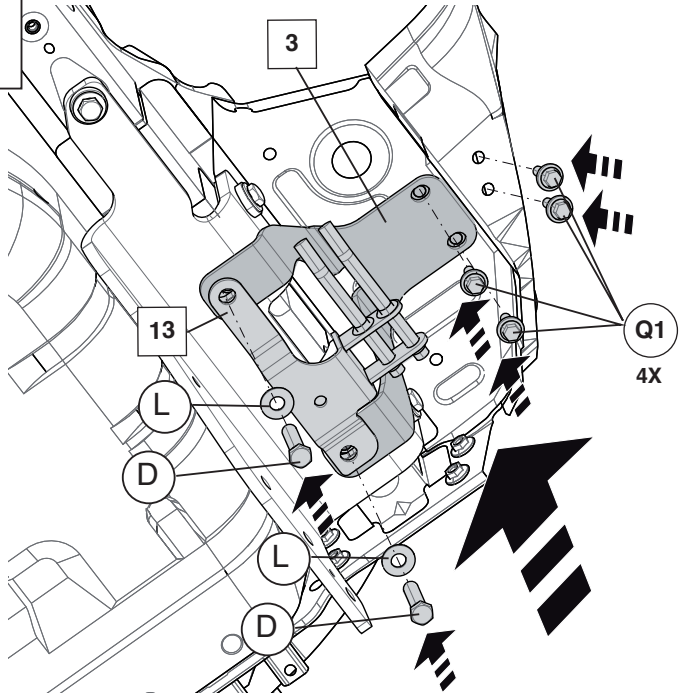

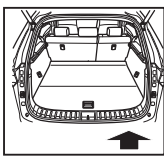

## Hybrid

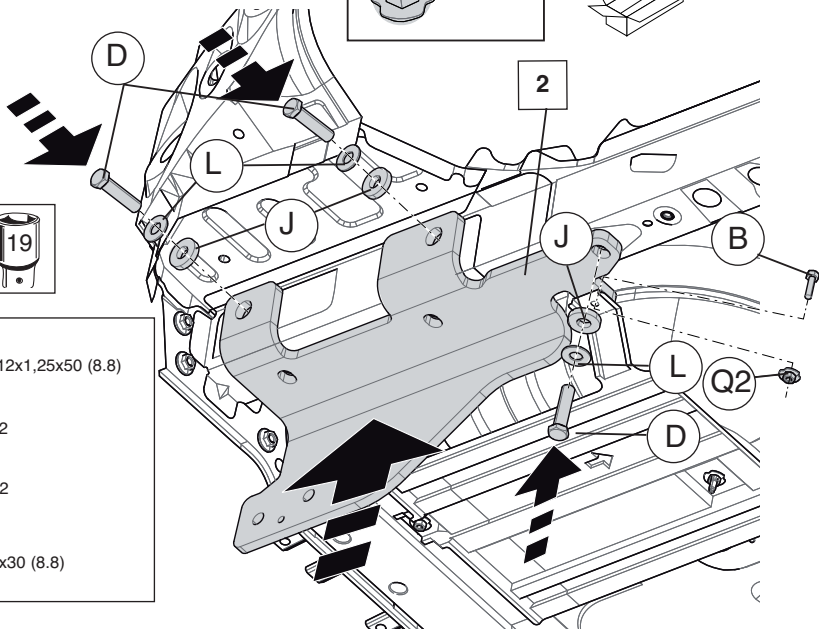
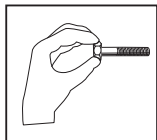
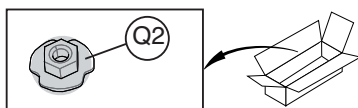

D (3x) M12x1,25x50 (8.8)

L (3x) M12

J (3x) M12

B (1x) M6x30 (8.8)

## Petrol

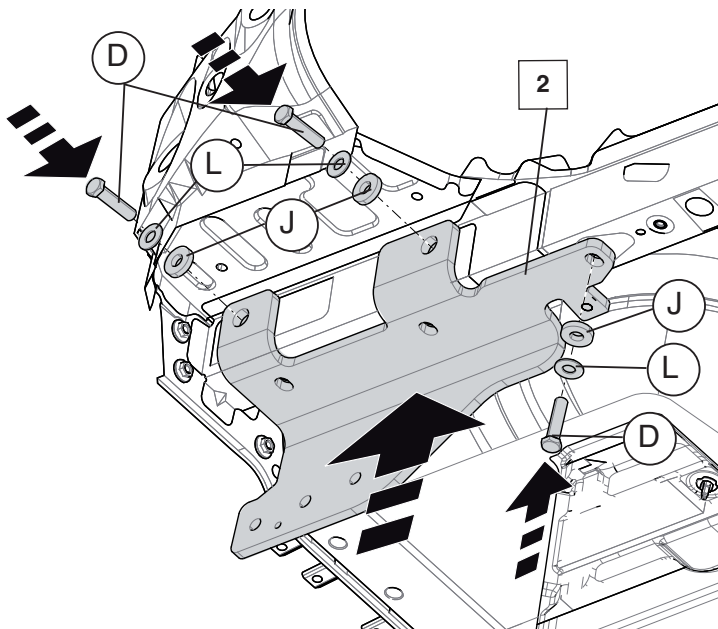

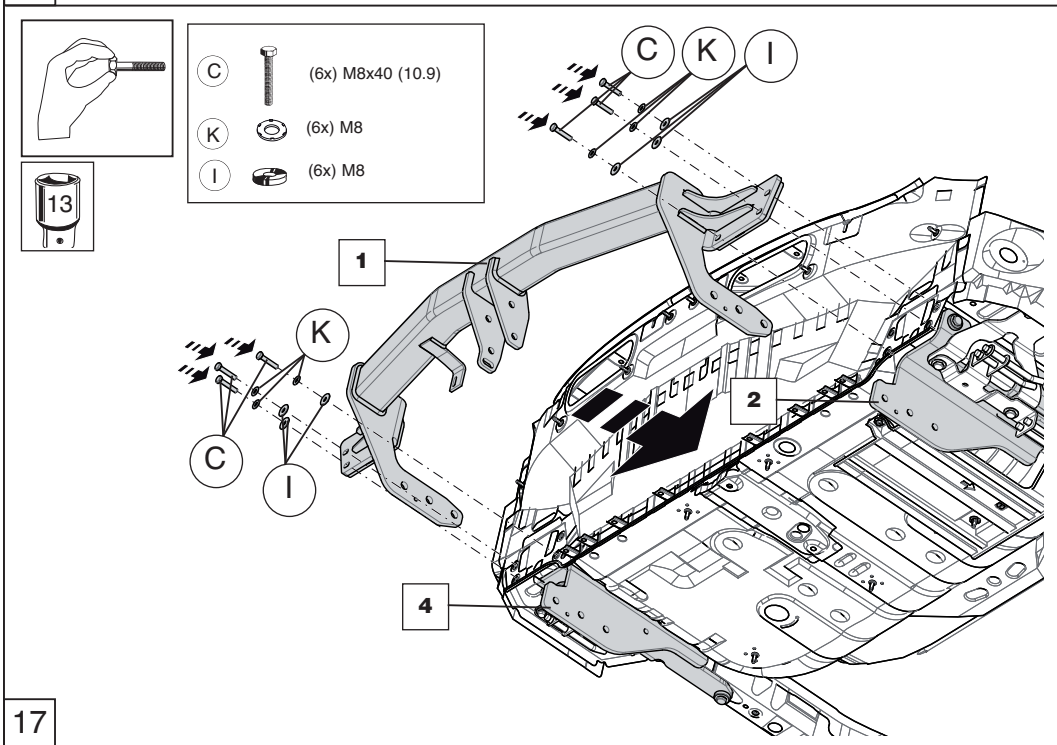
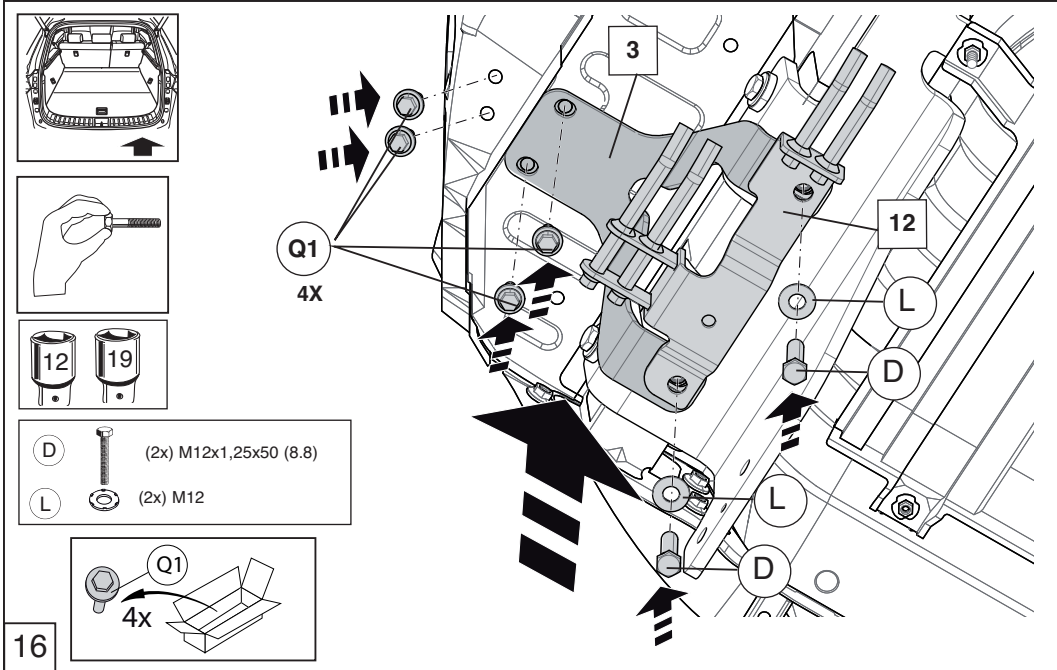



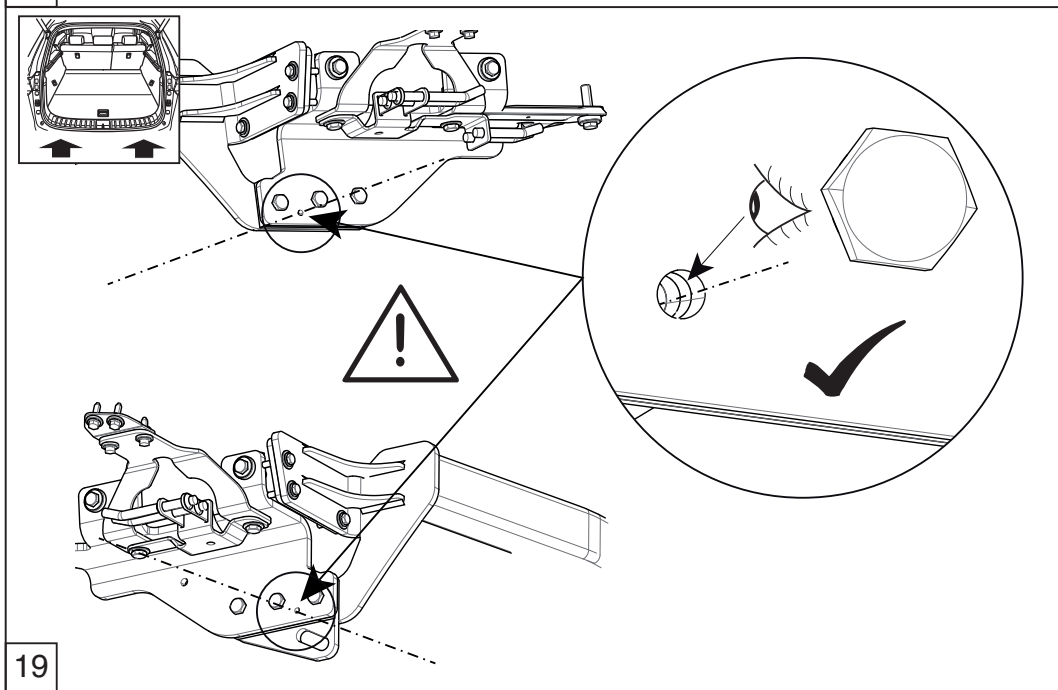
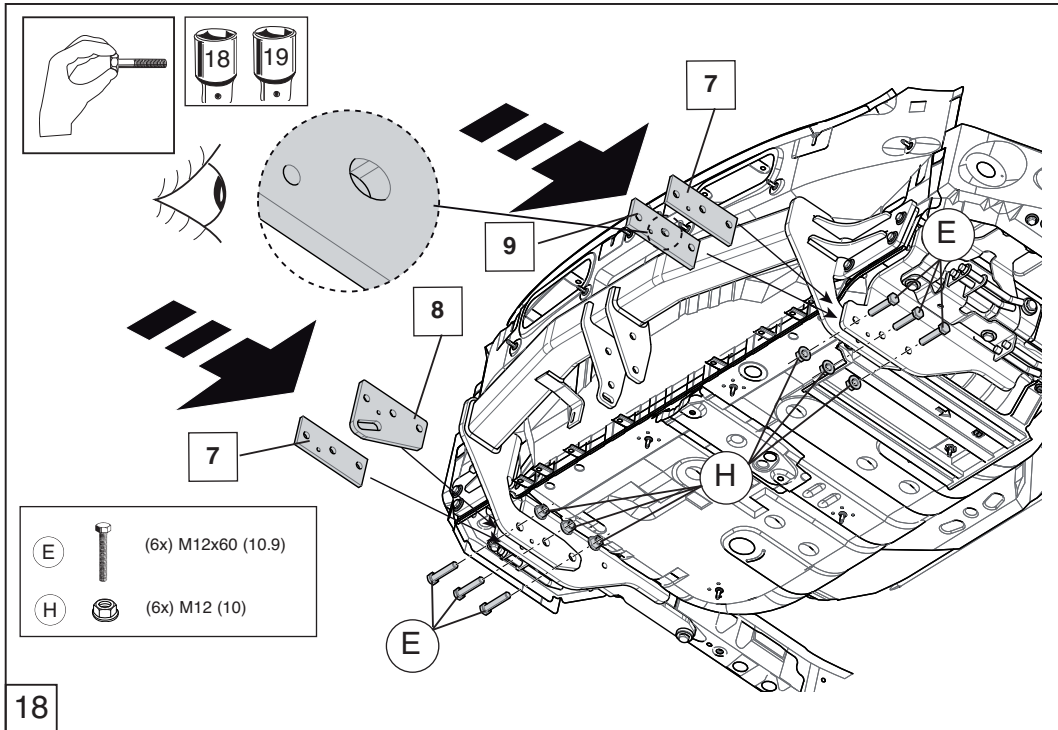

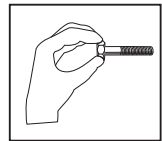
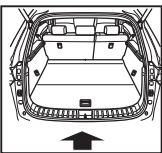

10

F (4x) M12x25 (100)

M (4x) M12

1

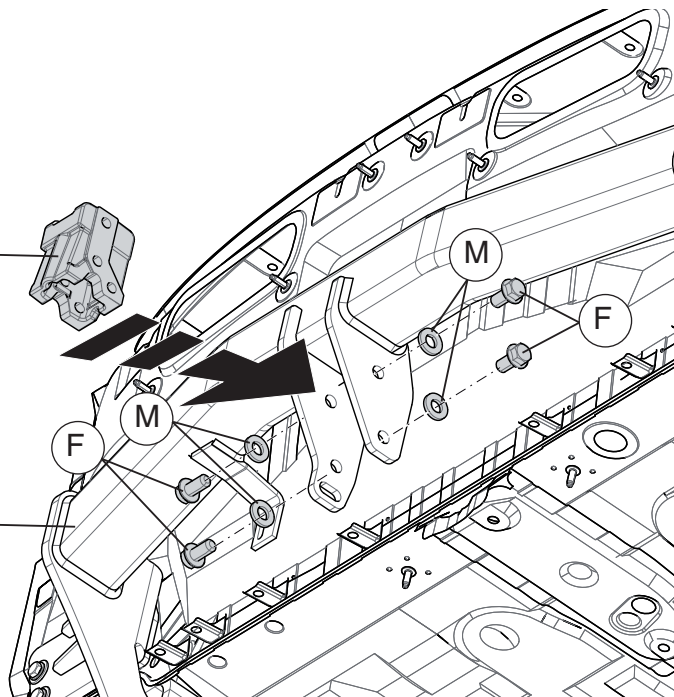

20

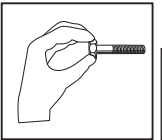
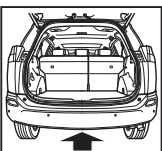

1

A (2x) M6x20 (10.9)

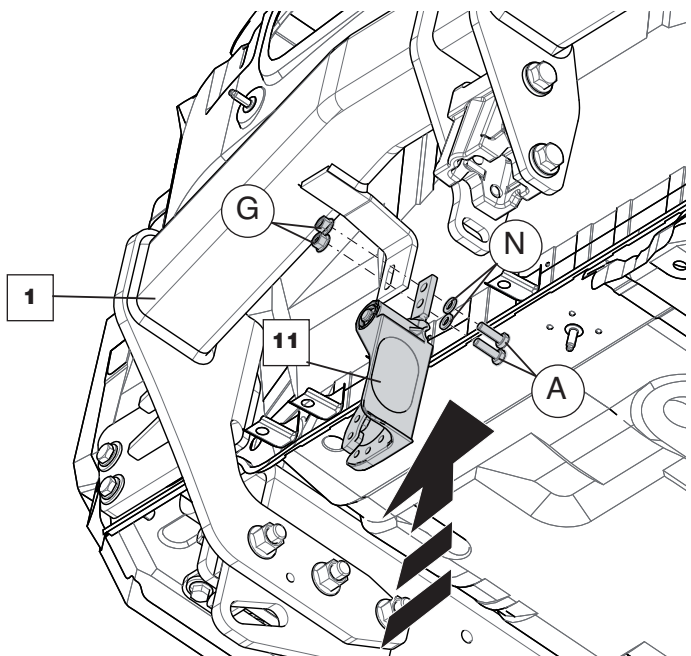

N (2x) M6

G (2x) M6 (10)

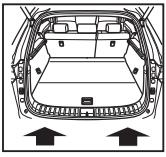

21



1→2→3→...		QTY	
<b>1</b> (C)	25Nm	3x	13
<b>2</b> (C)	25Nm	3x	13
<b>3</b> (E)	110Nm	1x	18/19
<b>4</b> (E)	110Nm	1x	18/19
<b>5</b> (E)	110Nm	1x	18/19
<b>6</b> (E)	110Nm	1x	18/19
<b>7</b> (E)	110Nm	1x	18/19
<b>8</b> (E)	110Nm	1x	18/19
<b>9</b> (D)	100Nm	2x	19
<b>10</b> (D)	100Nm	2x	19
<b>11</b> (D)	100Nm	3x	19
<b>12</b> (D)	100Nm	3x	19
<b>13</b> (Q1)	25Nm	4x	12
<b>14</b> (Q1)	25Nm	4x	12
<b>15</b> (F)	110Nm	4x	17
<b>16</b> (A)	15Nm	2x	10

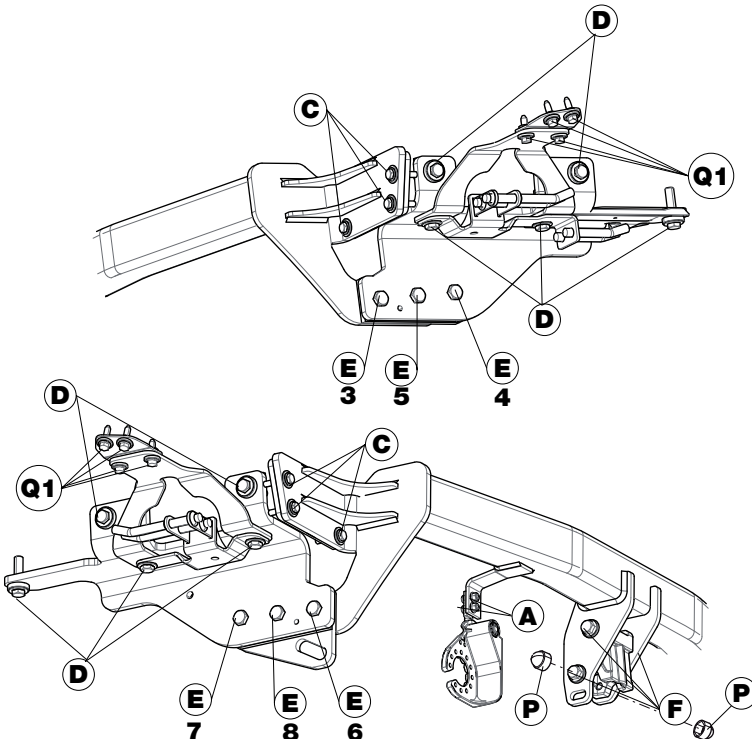

22

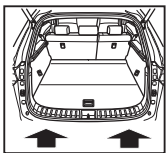

## Petrol

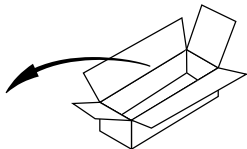
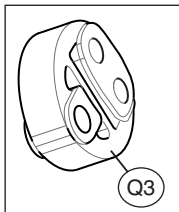
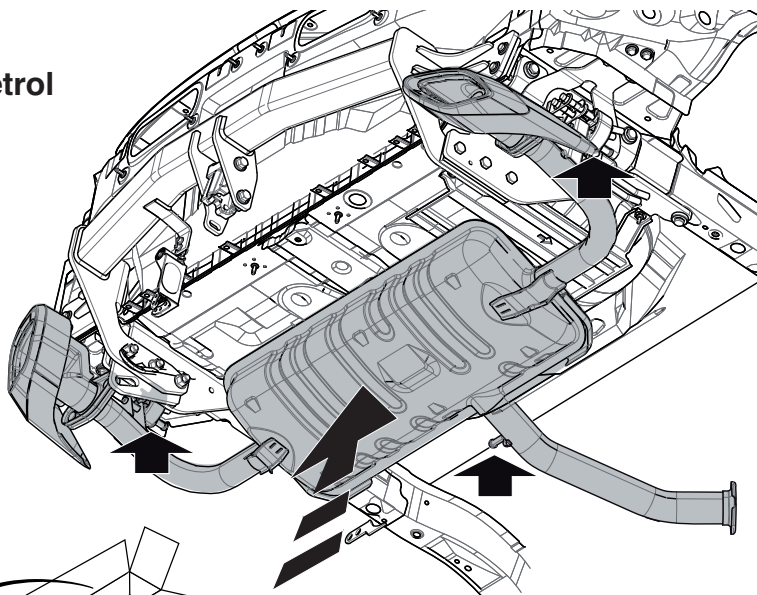

## Hybrid

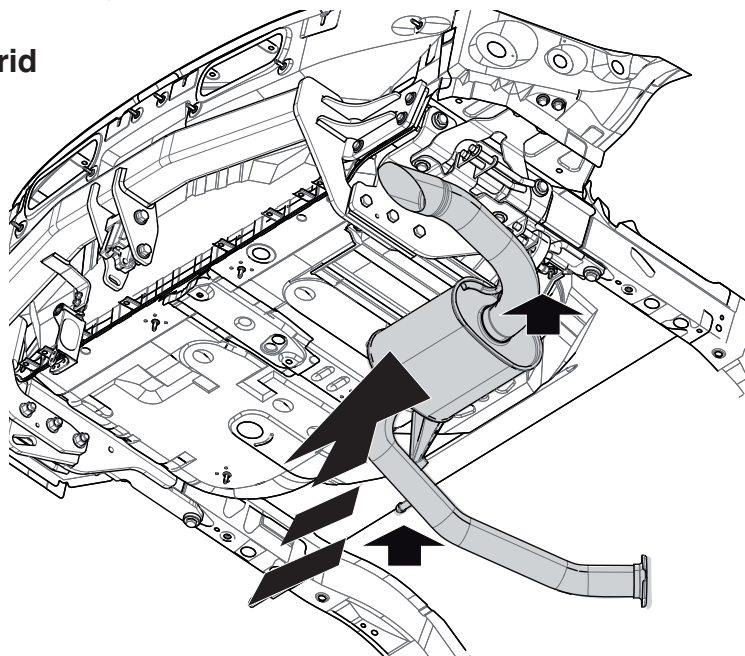

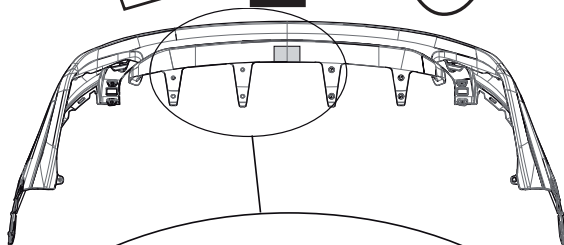
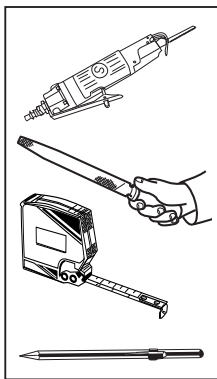

## Petrol

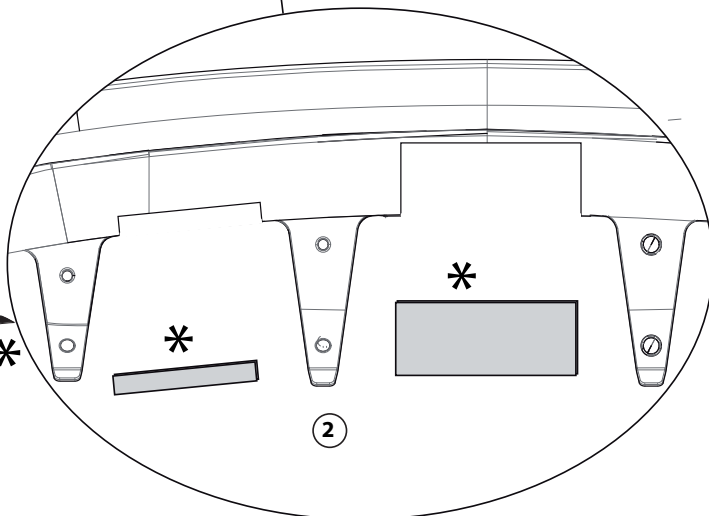
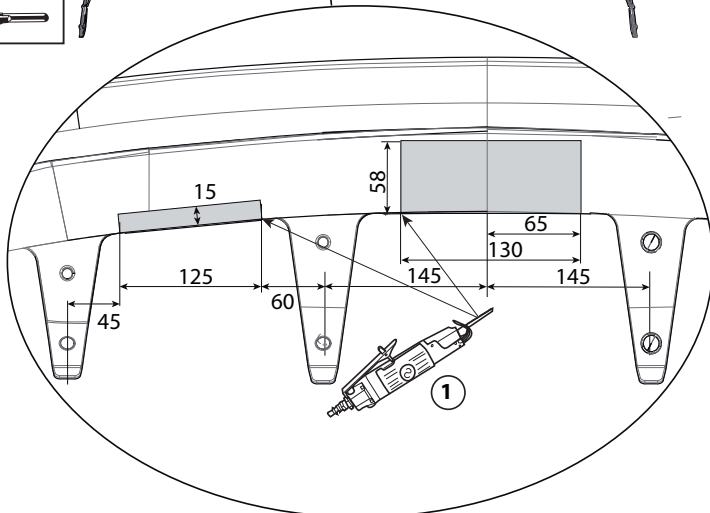

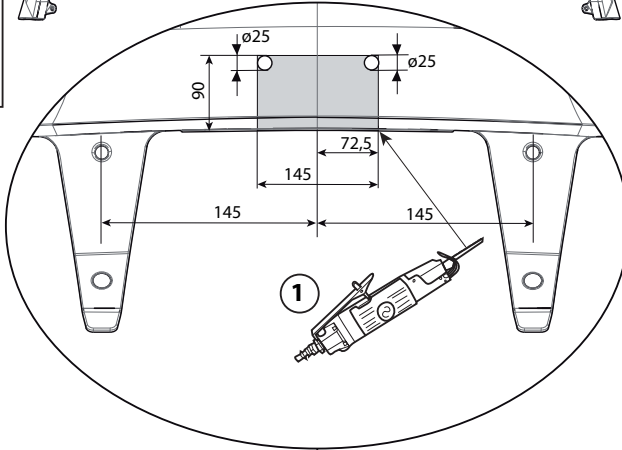
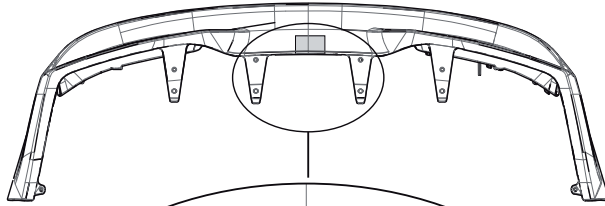
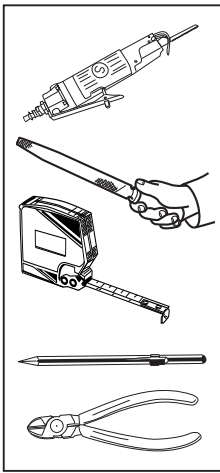

Hybrid

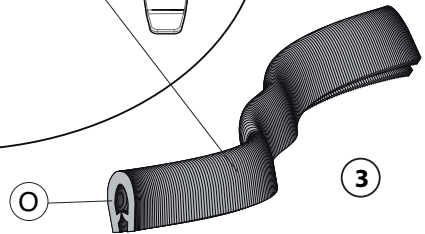
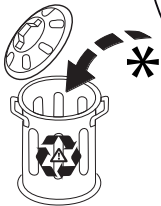
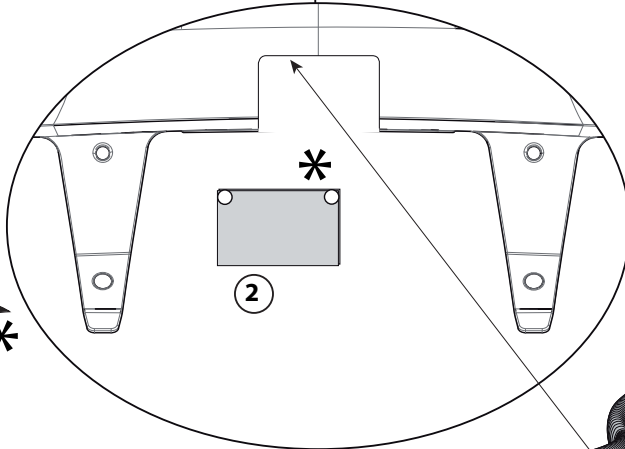

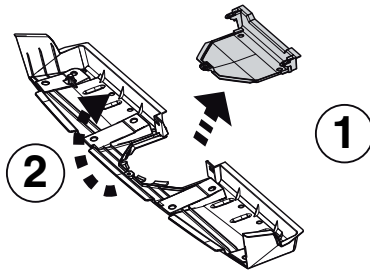
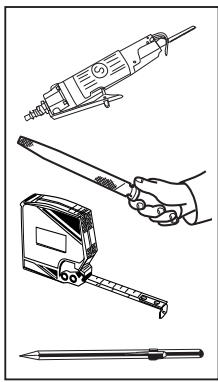

Petrol

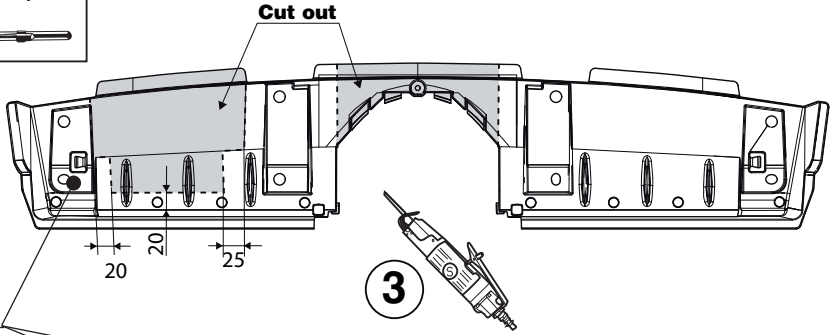

Outside

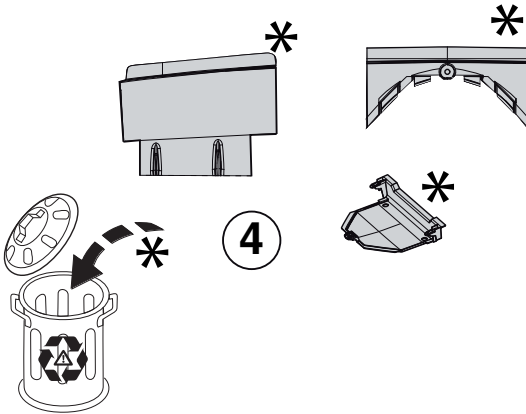
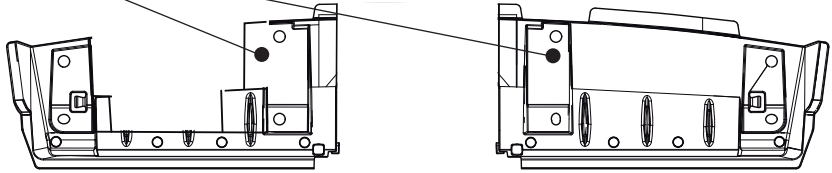

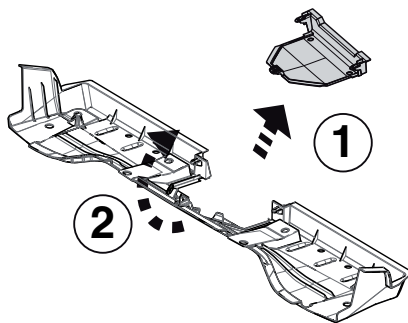
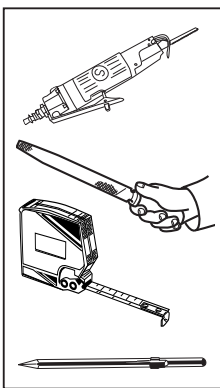

2

1

Hybrid

Cut out

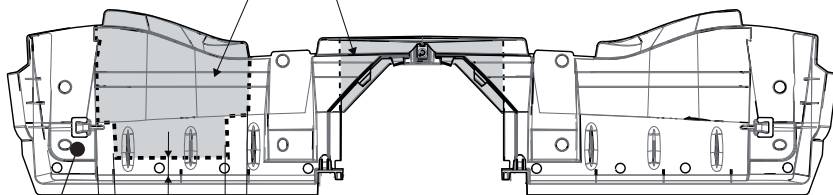

Outside

20

20

25

3

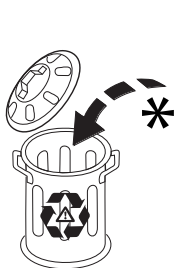
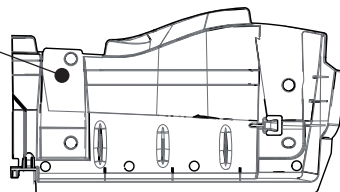
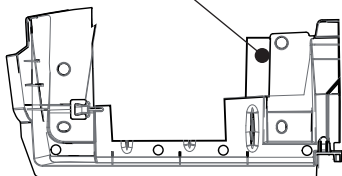
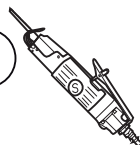



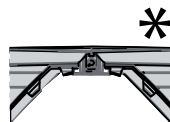
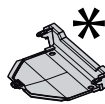
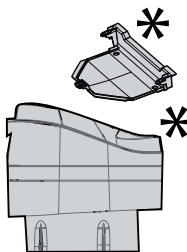





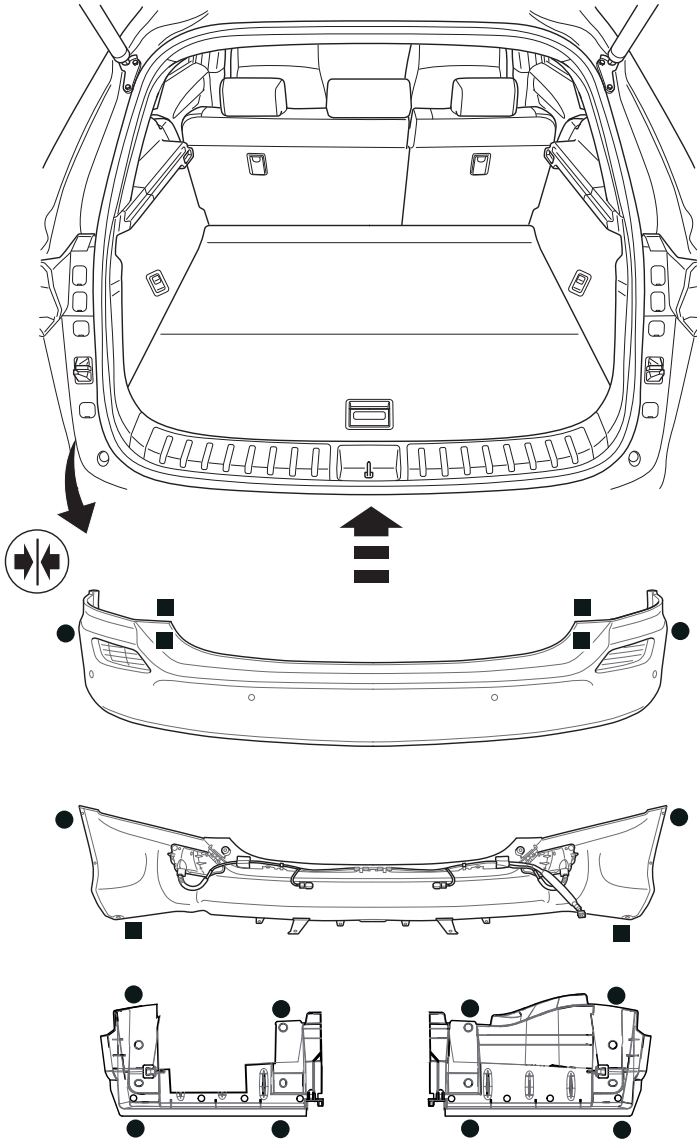



















4





	=			=			=			=	Installer Safety
	=			=			=			=	Customer Safety
	=			=			=			=	Regulation
	=			=			=			=	Attention



	=			=			=			=	Installer Safety
	=			=			=			=	Customer Safety
	=			=			=			=	Regulation
	=			=			=			=	Attention

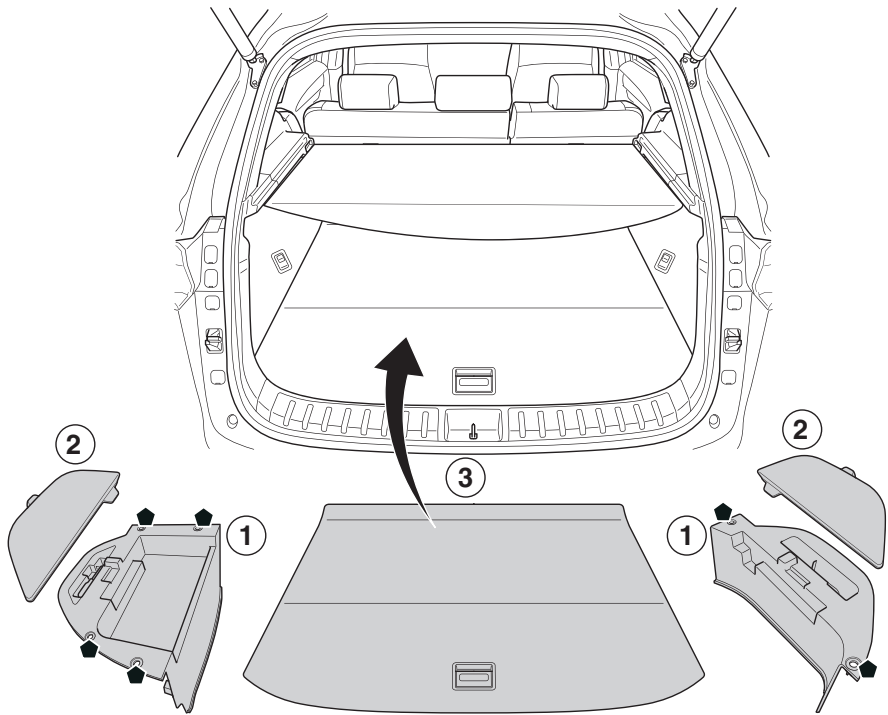

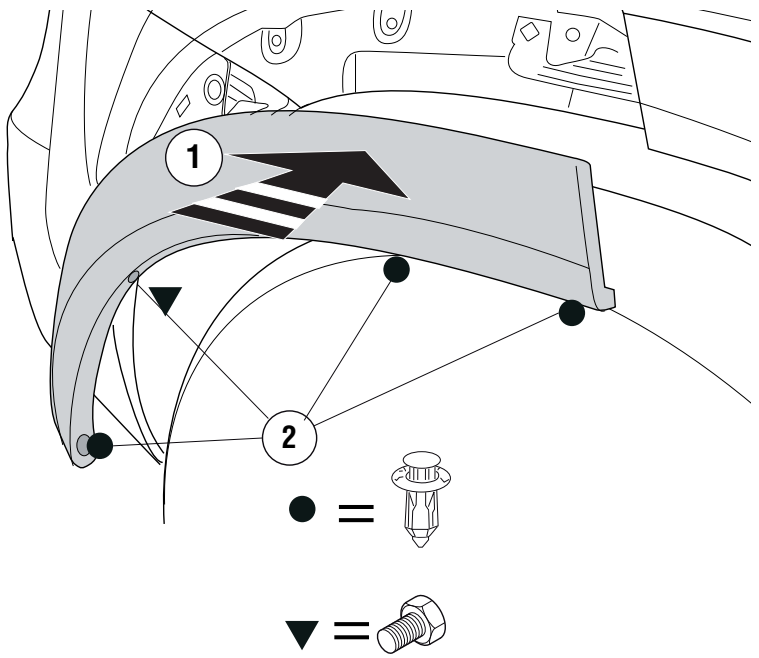
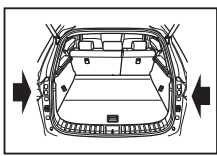

30

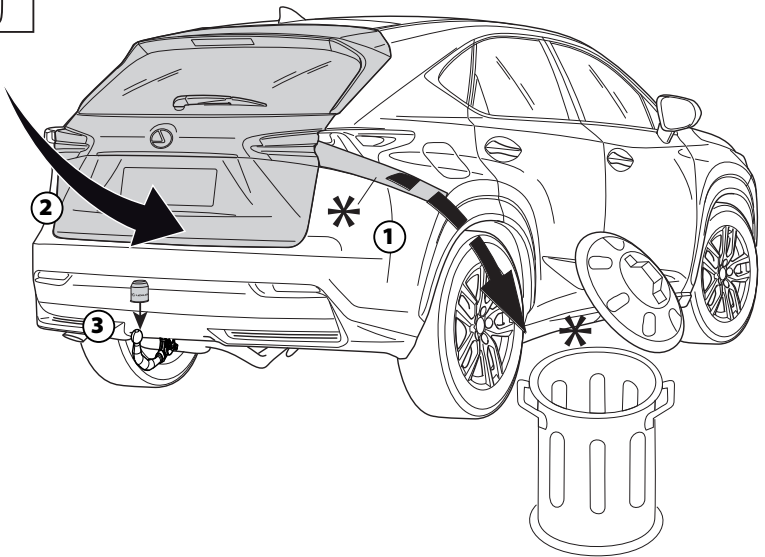
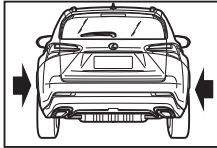

31

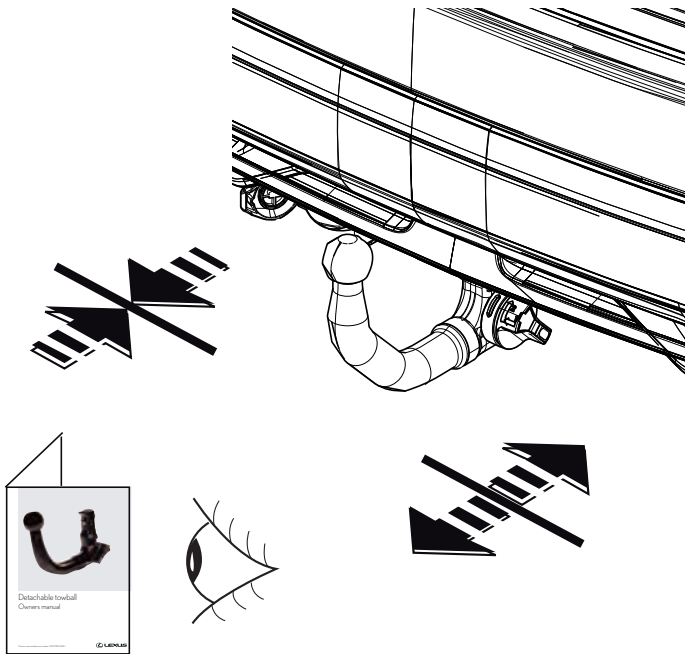

32

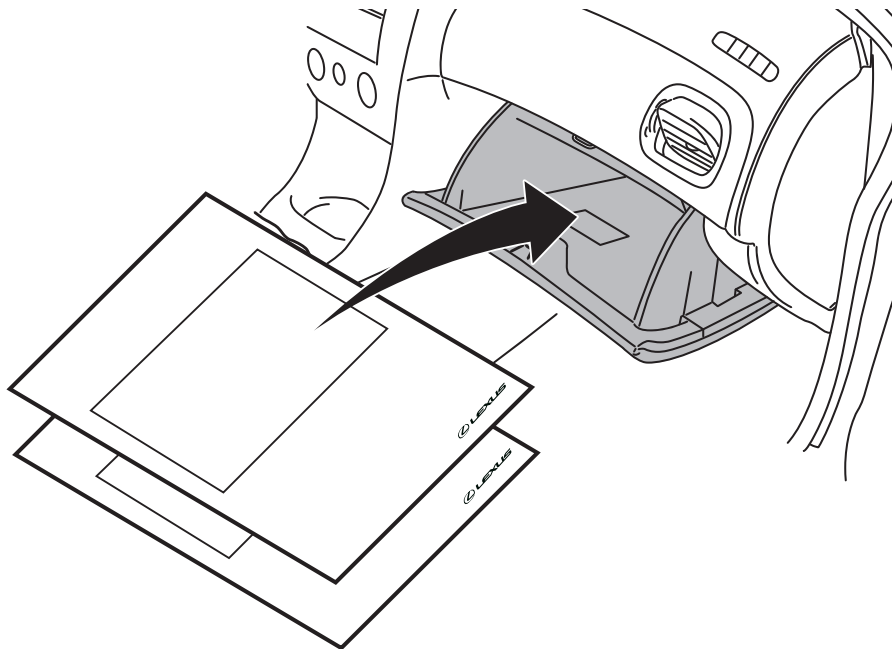

33

Dispositivo di traino tipo:  
Per autoveicoli:  
Tipo funzionale:

PZ408-X2550-00  
LEXUS NX; 07/2014  
AGZ1\*\*AW\*\*\*W / AYZ15\*-AW\*\*\*W

Classe e tipo di attacco:  
Omologazione:  
Valore D:  
Carico Verticale max. S:  
Larghezza rimorchiabile per Caravan e T.A.T.S.: 2,45m vedere CARTA di CIRCOLAZIONE VEICOLO (motrice) + 70 cm = ..arrotondare ai 5 cm

A50-X  
E11 55R 019847  
9,6 kN  
60 kg

Massa rimorchiabile:  
superiore (vedi D.M.28/05/85)  
vedi carta di circolazione dell' autoveicolo

**Per verificare l'idoneità del dispositivo di traino omologato a norma ECE/R55, all'installazione sulla vettura su cui si intende procedere al montaggio, compilare la seguente formula (se necessario declassare la massa rimorchiabile):**

$$D = \frac{T \times C}{T + C} \times 0,00981 \leq 9,6 \text{ kN}$$

dove: T= Massa Complessiva Max. della motrice (in kg)  
C= Massa Rimorchiabile Max. della motrice (in kg)

## DA COMPILARE PER IL COLLAUDO

**DICHIARAZIONE DI CORRETTO MONTAGGIO:** la sottoscritta Ditta dichiara di aver montato in maniera corretta ed in conformità alle prescrizioni sia del costruttore del veicolo che del costruttore del dispositivo stesso il seguente dispositivo di attacco meccanico:

tipo:.....  
Il dispositivo di attacco sopra indicato è stato installato su autoveicolo  
modello:.....  
targa:.....  
Data:.....

**TIMBRO e FIRMA**

**Si dichiara inoltre di aver informato l'utente del veicolo sull'USO e MANUTENZIONE del dispositivo stesso.**



# CHECK SHEET 1/2



Model / Year

Lexus NX 07/2014

Detachable  
Towing Hitch

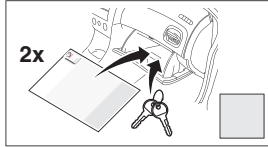
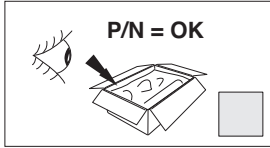

VIN n°



=A

=B



1→2→3→...	 CLICK	 A	 B	S/N
1 (C)	25Nm 3x	<input type="checkbox"/>	<input type="checkbox"/>	<input type="text"/>
2 (C)	25Nm 3x	<input type="checkbox"/>	<input type="checkbox"/>	<input type="text"/>
3 (E)	110Nm 1x	<input type="checkbox"/>	<input type="checkbox"/>	<input type="text"/>
4 (E)	110Nm 1x	<input type="checkbox"/>	<input type="checkbox"/>	<input type="text"/>
5 (E)	110Nm 1x	<input type="checkbox"/>	<input type="checkbox"/>	<input type="text"/>
6 (E)	110Nm 1x	<input type="checkbox"/>	<input type="checkbox"/>	<input type="text"/>
7 (E)	110Nm 1x	<input type="checkbox"/>	<input type="checkbox"/>	<input type="text"/>
8 (E)	110Nm 1x	<input type="checkbox"/>	<input type="checkbox"/>	<input type="text"/>

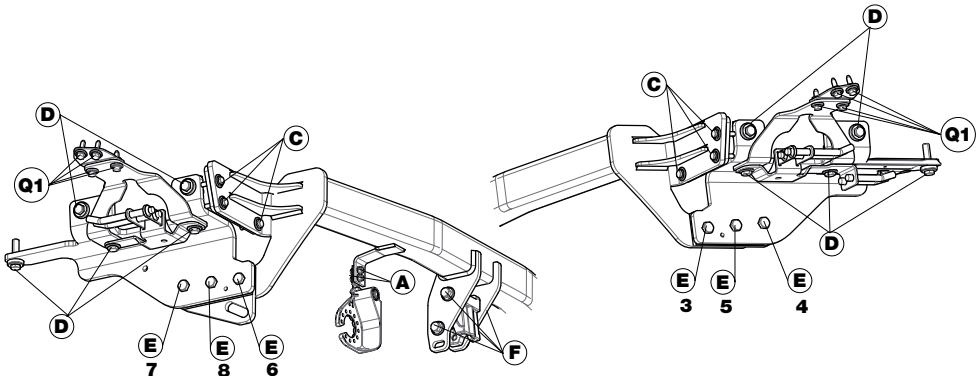

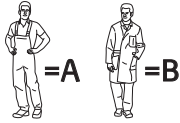

1→2→3→...	A	B	S/N	
9 <b>(D)</b>	100Nm 2x	<input type="checkbox"/>	<input type="checkbox"/>	
10 <b>(D)</b>	100Nm 2x	<input type="checkbox"/>	<input type="checkbox"/>	
11 <b>(D)</b>	100Nm 3x	<input type="checkbox"/>	<input type="checkbox"/>	
12 <b>(D)</b>	100Nm 3x	<input type="checkbox"/>	<input type="checkbox"/>	
13 <b>(Q1)</b>	25Nm 4x	<input type="checkbox"/>	<input type="checkbox"/>	
14 <b>(Q1)</b>	25Nm 4x	<input type="checkbox"/>	<input type="checkbox"/>	
15 <b>(F)</b>	110Nm 4x	<input type="checkbox"/>	<input type="checkbox"/>	
16 <b>(A)</b>	15Nm 2x	<input type="checkbox"/>	<input type="checkbox"/>	

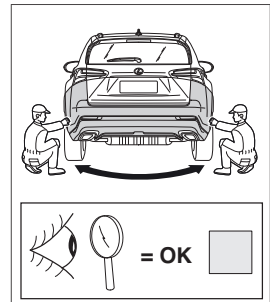
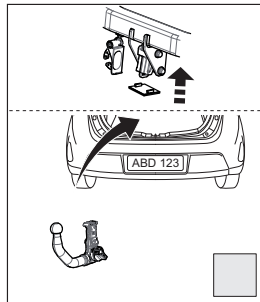
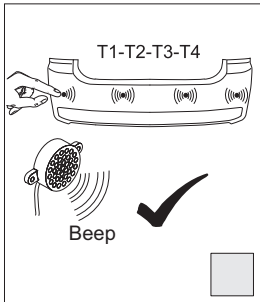
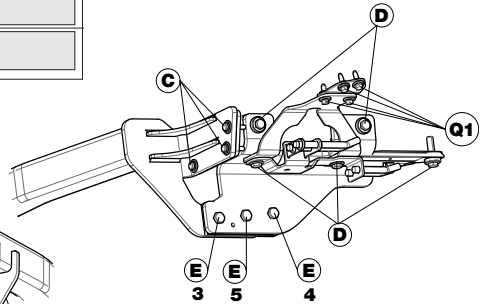
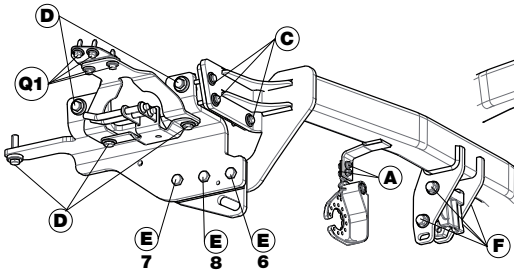

**Installation Date:**  
 . . . / . . . / . . .

**Technician Name & Signature:**

**Stamp:**